

# Live working — Gloves of insulating material

The European Standard EN 60903:2003 has the status of a  
British Standard

ICS 13.260; 29.240.20; 29.260.99

## National foreword

This British Standard is the official English language version of EN 60903:2003. It was derived by CENELEC from IEC 60903:2003, including Corrigendum January 2005. It supersedes BS EN 60903:1993 and BS EN 50237:2000 both of which are withdrawn.

The CENELEC common modifications have been implemented at the appropriate places in the text and are indicated by tags **[C]** **[C]**.

The UK participation in its preparation was entrusted to Technical Committee PEL/78, Tools for live working, which has the responsibility to:

- aid enquirers to understand the text;
- present to the responsible international/European committee any enquiries on the interpretation, or proposals for change, and keep the UK interests informed;
- monitor related international and European developments and promulgate them in the UK.

A list of organizations represented on this committee can be obtained on request to its secretary.

### Cross-references

The British Standards which implement international or European publications referred to in this document may be found in the *BSI Catalogue* under the section entitled “International Standards Correspondence Index”, or by using the “Search” facility of the *BSI Electronic Catalogue* or of British Standards Online.

This publication does not purport to include all the necessary provisions of a contract. Users are responsible for its correct application.

**Compliance with a British Standard does not of itself confer immunity from legal obligations.**

### Summary of pages

This document comprises a front cover, an inside front cover, the EN title page, pages 2 to 65 and a back cover.

The BSI copyright notice displayed in this document indicates when the document was last issued.

This British Standard was published under the authority of the Standards Policy and Strategy Committee on 17 February 2004

© BSI 2006

### Amendments issued since publication

Amd. No.	Date	Comments
15049 Corrigendum No. 1	11 March 2004	Revision of supersession information
16512 Corrigendum No. 2	31 August 2006	Correction to <b>8.4.1.1</b> and <b>9.2.2</b>

EUROPEAN STANDARD

**EN 60903**

NORME EUROPÉENNE

EUROPÄISCHE NORM

November 2003

ICS 13.260; 29.240.20; 29.260.99

Supersedes EN 60903:1992 + A11:1997 & EN 50237:1997

Incorporating Corrigendum January 2005

English version

**Live working -  
Gloves of insulating material**  
(IEC 60903:2002 + corrigendum 2003, modified)

Travaux sous tension -  
Gants en matériau isolant  
(CEI 60903:2002 + corrigendum 2003,  
modifiée)

Arbeiten unter Spannung -  
Handschuhe aus isolierendem Material  
(IEC 60903:2002 + Corrigendum 2003,  
modifiziert)

This European Standard was approved by CENELEC on 2003-07-01. CENELEC members are bound to comply with the CEN/CENELEC Internal Regulations which stipulate the conditions for giving this European Standard the status of a national standard without any alteration.

Up-to-date lists and bibliographical references concerning such national standards may be obtained on application to the Central Secretariat or to any CENELEC member.

This European Standard exists in three official versions (English, French, German). A version in any other language made by translation under the responsibility of a CENELEC member into its own language and notified to the Central Secretariat has the same status as the official versions.

CENELEC members are the national electrotechnical committees of Austria, Belgium, Czech Republic, Denmark, Finland, France, Germany, Greece, Hungary, Iceland, Ireland, Italy, Lithuania, Luxembourg, Malta, Netherlands, Norway, Portugal, Slovakia, Spain, Sweden, Switzerland and United Kingdom.

**CENELEC**

European Committee for Electrotechnical Standardization  
Comité Européen de Normalisation Electrotechnique  
Europäisches Komitee für Elektrotechnische Normung

**Central Secretariat: rue de Stassart 35, B - 1050 Brussels**

## Foreword

The text of document 78/462A/FDIS, future edition 2 of IEC 60903, prepared by IEC TC 78, Live working, was submitted to the IEC-CENELEC parallel vote and was approved by CENELEC as EN 60903 on 2003-07-01.

A draft amendment, prepared by the Technical Committee CENELEC TC 78, Equipment and tools for live working, was submitted to the formal vote and was approved by CENELEC for inclusion into EN 60903 on 2003-07-01.

This European Standard

- supersedes EN 60903:1992 + A11:1997, covering insulating gloves (and mitts) which would normally be used in conjunction with leather protector gloves worn over the insulating gloves (and mitts) to provide mechanical protection,
- supersedes EN 50237:1997, covering gloves (and mitts) which combine in one unique glove the insulating properties of elastomer gloves and the mechanical properties of leather gloves. The result of the combination is defined as a composite glove;
- includes requirements and testing for a "long composite glove" which extends protection to most of the upper arm.

The following dates were fixed:

- latest date by which the EN has to be implemented at national level by publication of an identical national standard or by endorsement (dop) 2004-07-01
- latest date by which the national standards conflicting with the EN have to be withdrawn (dow) 2006-07-01

This European Standard was prepared under a mandate given to CENELEC by the European Commission and the European Free Trade Association and supports the essential requirements of Directive 89/686/EEC.

NOTE Subclauses which are additional to those in IEC 60903 are prefixed "Z".

Annexes designated "normative" are part of the body of the standard.

Annexes designated "informative" are given for information only.

In this standard, annexes A, B, C and ZA are normative and annexes D, E, F, G, H and I are informative.

Annex ZA has been added by CENELEC.

---

## Endorsement notice

The text of the International Standard IEC 60903:2002 and its corrigendum February 2003 was approved by CENELEC as a European Standard with agreed common modifications.

---

## CONTENTS

INTRODUCTION.....	6
1 Scope.....	7
2 Normative references .....	7
3 Definitions .....	8
4 Classification.....	10
5 General requirements.....	11
5.1 Physical requirements .....	11
5.1.1 Composition .....	11
5.1.2 Shape.....	11
5.1.3 Dimensions .....	11
5.1.4 Thickness .....	12
5.1.5 Workmanship and finish .....	13
5.2 Mechanical requirements.....	13
5.2.1 Tensile strength and elongation at break .....	13
5.2.2 Tension set.....	13
5.3 Electrical requirements .....	13
5.4 Ageing requirements .....	14
5.5 Thermal requirements .....	14
5.5.1 Low temperature resistance.....	14
5.5.2 Flame retardancy.....	15
5.6 Gloves with special properties .....	15
5.6.1 Acid resistance .....	15
5.6.2 Oil resistance .....	15
5.6.3 Ozone resistance.....	15
5.6.4 Acid, oil and ozone resistance .....	15
5.6.5 Extremely low temperature resistance .....	15
5.7 Marking .....	16
5.8 Packaging .....	17
6 Specific mechanical requirements .....	17
6.1 Insulating gloves – Resistance to mechanical puncture .....	17
6.2 Composite gloves.....	17
6.2.1 Resistance to mechanical puncture .....	17
6.2.2 Abrasion resistance .....	17
6.2.3 Cutting resistance.....	17
6.2.4 Tear resistance.....	18
7 Electrical requirements for long composite gloves .....	18
8 General testing .....	19
8.1 General .....	19
8.2 Visual inspection and measurements.....	19
8.2.1 Shape.....	19
8.2.2 Dimensions .....	19
8.2.3 Thickness .....	20
8.2.4 Workmanship and finish .....	20

8.3	Mechanical tests .....	20
8.3.1	Tensile strength and elongation at break .....	20
8.3.2	Resistance to mechanical puncture .....	21
8.3.3	Tension set.....	21
8.4	Dielectric tests .....	22
8.4.1	General .....	22
8.4.2	AC test procedure.....	23
8.4.3	DC test procedure .....	24
8.5	Ageing test.....	25
8.6	Thermal tests .....	25
8.6.1	Low temperature test.....	25
8.6.2	Flame retardancy test.....	25
8.7	Tests on gloves with special properties .....	26
8.7.1	Category A – Acid resistance.....	26
8.7.2	Category H – Oil resistance .....	26
8.7.3	Category Z – Ozone resistance .....	27
8.7.4	Category C – Extremely low temperature resistance.....	27
8.8	Marking .....	27
8.9	Packaging .....	27
9	Specific mechanical testing .....	27
9.1	Abrasion resistance.....	27
9.2	Cutting resistance .....	28
9.2.1	Test on reference test piece .....	29
9.2.2	Test on glove test piece.....	29
9.3	Tear resistance .....	30
10	Leakage current test.....	31
10.1	General test conditions.....	31
10.2	Test arrangement .....	31
10.3	Test procedure .....	32
11	Quality assurance plan and acceptance tests .....	32
11.1	General .....	32
11.2	Categories of tests .....	32
11.3	Sampling procedure .....	32
11.4	Acceptance tests.....	32
	Annex A (normative) List and classification of tests .....	48
	Annex B (normative) Liquid for tests on gloves of category H – Oil resistance .....	51
	Annex C (normative) Sampling procedure.....	52
	Annex D (informative) Guidelines for the selection of the class of glove in relation to nominal voltage of a system .....	54
	Annex E (informative) In-service recommendations.....	55
	Annex F (informative) Typical glove dimensions.....	57
	Annex G (informative) Cotton canvas additional characteristics .....	58
	Annex H (informative) Acceptance tests.....	60
	Annex I (informative) Electrical limits for the use of gloves of insulating material .....	61
	Annex ZA (normative) Normative references to international publications with their corresponding European publications .....	63
	Bibliography.....	65

Figure 1 – Examples of typical shapes of gloves .....	33
Figure 2 – Shape of mitts .....	34
Figure 3 – Contour of glove (see 8.2.2) .....	35
Figure 4 – Example of area usually in contact with energized equipment .....	36
Figure 5 – Marking symbols (see 5.7) .....	37
Figure 6 – Dumb-bell test piece for mechanical tests (see 8.3.1 and 8.3.3) .....	38
Figure 7 – Test plates and needle for resistance to mechanical puncture (see 8.3.2) .....	39
Figure 8 – Distance $D$ from open part of glove to water line (see 8.4.1.1) .....	40
Figure 9 – Bend (fold) line for low and extremely low temperature test (see 8.6.1 and 8.7.4) .....	41
Figure 10 – Polyethylene plates for low and extremely low temperature test (see 8.6.1 and 8.7.4) .....	42
Figure 11 – Set-up for the flame retardancy test (see 8.6.2) .....	43
Figure 12 – Abrasion resistance tester (see 9.1) .....	44
Figure 13 – Apparatus for testing cutting resistance (see 9.2) .....	45
Figure 14 – Test piece direction and location for tear resistance (see 9.3) .....	46
Figure 15 – Shape of test piece for tear resistance (see 9.3) .....	46
Figure 16 – Set-up for the leakage current test (see 10.2) .....	47
Table 1 – Special properties .....	11
Table 2 – Standard lengths of gloves .....	12
Table 3 – Maximum thickness of the gloves .....	12
Table 4 – Proof test and withstand test .....	14
Table 5 – Surface leakage current test for long composite gloves .....	19
Table 6 – Clearance from open part of the glove to water line .....	23
Table 7 – Presentation of test results on glove test piece .....	30
Table A.1 – General test procedure .....	48
Table B.1 – Characteristics of oil no. 1 .....	51
Table C.1 – Classification of defects .....	52
Table C.2 – Sampling plan for minor defects .....	53
Table C.3 – Sampling plan for major defects .....	53
Table D.1 – Designation of maximum use voltage .....	54
Table E.1 – Distances between the cuff of the protector glove and the top of the cuff of the insulating glove .....	55
Table F.1 – Details and dimensions (see Figures 1 and 2) .....	57
Table G.1 – Identification sheet .....	59
Table I.1 – Electrical limits .....	62

## INTRODUCTION

In this document, the clauses on requirements and testing are reorganized in order to bring together the common requirements and tests, then to lay down separately those which are specific to insulating gloves for electrical protection normally worn under leather protector gloves as opposed to those specific to insulating gloves for combined electrical and mechanical protection. This arrangement meets the basic necessity that a same quality level of electrical insulation is achieved for all types of insulating gloves.

This document has been prepared according to the requirements of IEC 61477 where applicable.



## LIVE WORKING – GLOVES OF INSULATING MATERIAL

### 1 Scope

This International Standard is applicable to:

- insulating gloves and mitts which should normally be used in conjunction with leather protector gloves worn over the insulating gloves to provide mechanical protection;
- insulating gloves and mitts usable without over-gloves for mechanical protection.

Unless otherwise stated, the use of the term “glove” includes both gloves and mitts. The use of the term “insulating gloves” designates gloves providing electrical protection only. The use of the term “composite gloves” designates gloves providing electrical and mechanical protection.

### 2 Normative references

The following referenced documents are indispensable for the application of this document. For dated references, only the edition cited applies. For undated references, the latest edition of the referenced document (including any amendments) applies.

IEC 60050(151):2001, *International Electrotechnical Vocabulary (IEV) – Part 151: Electrical and magnetic devices*

IEC 60050(601):1985, *International Electrotechnical Vocabulary (IEV) – Chapter 601: Generation, transmission and distribution of electricity – General*

IEC 60050(651):1999, *International Electrotechnical Vocabulary (IEV) – Part 651: Live working*

IEC 60060-1:1989, *High-voltage test techniques – Part 1: General definitions and test requirements*

IEC 60060-2:1994, *High-voltage test techniques – Part 2: Measuring systems*

IEC 60212:1971, *Standard conditions for use prior to and during the testing of solid electrical insulating materials*

IEC 60417 (all parts), *Graphical symbol for use on equipment*

IEC 60743:2001, *Live working – Terminology for tools, equipment and devices*

IEC 61318:1994, *Live working – Guidelines for quality assurance plans*

IEC 61477:2001, *Live working - Minimum requirements for the utilization of tools, devices and equipment*

ISO 37:1994, *Rubber, vulcanized or thermoplastic – Determination of tensile stress-strain properties*

ISO 472:1999, *Plastics – Vocabulary*

ISO 2592:2000, *Determination of flash and fire points – Cleveland open cup method*

ISO 2859-1:1999, *Sampling procedures for inspection by attributes – Part 1: Sampling schemes indexed by acceptance quality limit (AQL) for lot-by-lot inspection*

ISO 2977:1997, *Petroleum products and hydrocarbon solvents – Determination of aniline point and mixed aniline point*

ISO 3104:1994, *Petroleum products – Transparent and opaque liquids – Determination of kinematic viscosity and calculation of dynamic viscosity*

ISO 9000:2000, *Quality management systems – Fundamentals and vocabulary*

ISO 9001:2000, *Quality management systems – Requirements*

ISO 9004:2000, *Quality management systems – Guidelines for performance improvements*

### **3 Definitions**

For the purposes of this document, the following terms and definitions apply.

#### **3.1**

##### **composite gloves**

insulating gloves made with integrated mechanical protection

[IEV 651-07-11 modified and definition 8.3.1 of IEC 60743]

#### **3.2**

##### **insulating gloves**

gloves made of elastomer or plastic material, used for the protection of the worker against electrical hazards

[IEV 651-07-09 and definition 8.2.3 of IEC 60743]

#### **3.3**

##### **long composite gloves**

composite gloves used to extend the protection of the worker over the arms up to the armpits

[Definition 8.3.2 of IEC 60743]

#### **3.4**

##### **mitt**

glove with multiple fingers enclosed in one covering

#### **3.5**

##### **bell cuff glove**

glove with an enlarged shape from the wrist to the cuff in such a way as to facilitate pull-on over a thick garment

**3.6****contour glove**

glove shaped at the upper part of the gauntlet in such a way as to facilitate the bending of the arm

**3.7****curved glove**

glove on which the fingers are slightly bent in a position corresponding to the position the hand forms when while holding an object

**3.8****lined glove**

glove with an inside lining of textile attached to the plastic or to the elastomer

**3.9****elastomer**

generic term that includes rubber, latex and elastomeric compounds that may be natural or synthetic or a mixture or a combination of both

[Definition 2.4.3 of IEC 60743]

**3.10****plastic**

material which contains, as an essential ingredient, a high polymer and which at some stage in its processing into finished products can be shaped by flow

NOTE 1 Elastomeric materials which are also shaped by flow, are not considered as plastics.

NOTE 2 In some countries, particularly in the United Kingdom, it is a permitted option to use the term "plastics" as the singular form as well as the plural form.

[ISO 472 and definition 2.4.4 of IEC 60743]

**3.11****cuff**

open part of a glove above the gauntlet

**3.12****cuff roll**

roll or reinforced edge of a glove at the cuff

**3.13****fork**

part of glove at the junction of two fingers, or finger and thumb

**3.14****gauntlet**

part of a glove from the wrist to the open part of the glove

**3.15****palm**

part of glove covering the face of the central inside hand

**3.16****wrist**

the narrowest part of the glove above the cuff

**3.17**

**disruptive discharge**

passage of an arc following dielectric breakdown

NOTE 1 The term “sparkover” (in French “amorçage”) is used when a disruptive discharge occurs in a gaseous or liquid dielectric.

NOTE 2 The term “flashover” (in French “contournement”) is used when a disruptive discharge occurs at least partly along the surface of a solid dielectric surrounded by a gaseous or liquid medium.

NOTE 3 The term “puncture” (in French “perforation”) is used when a disruptive discharge occurs through a solid dielectric producing permanent damage.

[IEV 651-01-18 and definition 2.7.7 of IEC 60743, modified]

**3.18**

**nominal voltage (of a system)**

suitable approximate value of voltage used to designate or identify a system

[IEV 601-01-21]

**3.19**

**proof test voltage**

specified voltage that is applied to a device for the time defined under specified conditions to assure that the electrical strength of the insulation is above a specified value

**3.20**

**withstand test voltage**

voltage that the device withstands without disruptive discharge, or other electric failure when voltage is applied under specified conditions

**3.21**

**acceptance test**

contractual test to prove to the customer that the device meets certain conditions of its specification

[IEV 151-16-23, modified]

**3.22**

**routine test**

test to which each individual device is subjected during or after manufacture to ascertain whether it complies with certain criteria

**3.23**

**sampling test**

test on a number of devices taken at random from a batch

**3.24**

**type test**

test on one or more devices made to a certain design to show that the design meets certain specifications

**4 Classification**

The gloves covered under this standard shall be designated as follows:

- by class, as class 00, class 0, class 1, class 2, class 3 and class 4;
- by special properties, by the addition of a suffix as shown in Table 1.

For composite gloves, only classes 00, 0 and 1 are available at the present time. At higher classes, additional data are needed. For long composite gloves, only classes 1, 2 and 3 are available at the present time.

Guidance as to temperature range at which gloves can be used is given in Annex E.

**Table 1 – Special properties**

Category	Resistant to
A	Acid
H	Oil
Z	Ozone
R	Acid, oil, ozone
C	Extremely low temperature
NOTE 1 Category R combines the characteristics of categories A, H and Z.	
NOTE 2 Any combination of categories may be used.	

## 5 General requirements

### 5.1 Physical requirements

#### 5.1.1 Composition

All gloves may be lined or unlined, have an exterior covering, or not, for protection against chemical attack, or be specially compounded to reduce the effects of ozone.

Insulating gloves for electrical protection are usually made of elastomer.

Composite gloves are usually made of elastomer or plastic. In case of excessive wear or damage on the exterior of a composite glove made up of layers of different colours, the different colour layer underneath will appear.

#### 5.1.2 Shape

The gloves shall be provided with a cuff. Gloves may be manufactured with or without cuff roll.

NOTE The shape of a glove is indicated in Figure 1a. The letter "h" in Figure 1a represents the curve of the finger in curved gloves. The shape of a mitt is indicated in Figure 2. The shape of a long composite glove is indicated in Figure 1b. The shape of a bell cuff glove is illustrated in Figure 1c.

#### 5.1.3 Dimensions

Table 2 gives the standard lengths of gloves.

Table 2 – Standard lengths of gloves

Class	Standard length mm <sup>b</sup>				
	00	280	360	–	–
0	280	360	410	460	–
1	–	360	410	460	800 <sup>a</sup>
2	–	360	410	460	800 <sup>a</sup>
3	–	360	410	460	800 <sup>a</sup>
4	–	–	410	460	–

<sup>a</sup> Long composite gloves.

<sup>b</sup> The permissible variation in length shall be  $\pm 15$  mm for any class, except for long composite gloves where permissible variation shall be  $\pm 20$  mm.

For contour-cuff gloves, the difference between the maximum and minimum lengths (see Figure 3) shall be  $50 \text{ mm} \pm 6 \text{ mm}$  except for long composite gloves where this difference shall be  $100 \text{ mm} \pm 12 \text{ mm}$ .

It is not practicable to specify other dimensions, but typical glove dimensions are suggested in Annex F.

#### 5.1.4 Thickness

The minimum thickness shall be determined only by the ability to pass the dielectric tests defined in 5.3.

The maximum thickness on the flat surface of a glove (no ribbed area if present) shall be as given in Table 3 in order to obtain the appropriate flexibility.

Table 3 – Maximum thickness of the gloves

Class	Thickness mm		
	Insulating gloves	Composite gloves	Long composite gloves
00	0,50	1,8	
0	1,00	2,3	
1	1,50	<sup>a</sup>	3,1
2	2,30		4,2
3	2,90	–	4,2
4	3,60	–	

<sup>a</sup> Under consideration.

Gloves of categories A, H, Z and R may require additional thickness which shall not exceed 0,6 mm.

### **5.1.5 Workmanship and finish**

Gloves shall be free on both inner and outer surfaces from harmful physical irregularities that can be detected by thorough test and inspection.

Harmful physical irregularities shall be defined as any feature that disrupts the uniform, smooth surface contour, such as pinholes, cracks, blisters, cuts, conductive embedded foreign matter, creases, pinch marks, voids (entrapped air), prominent ripples and prominent mould marks.

The working area is defined as all finger and thumb forks, the palm and the palm side of the fingers and thumb (see Figure 4).

Palm and finger surfaces designed to improve the grip shall not be considered as irregularities.

## **5.2 Mechanical requirements**

These requirements are applicable to the basic glove or sample material taken from the finished glove.

### **5.2.1 Tensile strength and elongation at break**

The average tensile strength shall not be less than 16 MPa (see 8.3.1).

The average elongation at break shall not be less than 600 % (see 8.3.1).

### **5.2.2 Tension set**

The tension set shall not exceed 15 % (see 8.3.3).

## **5.3 Electrical requirements**

All gloves shall pass the proof and withstand voltage tests along with the a.c. proof test current requirements, as specified in Table 4 and Clause 8, according to their class.

Table 4 – Proof test and withstand test

Class of gloves <sup>d</sup>	AC tests					DC tests		
	Proof test voltage	Maximum proof test current <sup>b, c</sup> mA rms				Withstand test voltage	Proof test voltage	Withstand test voltage
		Glove length mm						
	kV rms	280	360	410	≥ 460	kV rms	Avg kV	Avg kV
00	2,5	12	14	N/a <sup>a</sup>	N/a	5	4	8
0	5	12	14	16	18	10	10	20
1	10	N/a	16	18	20	20	20	40
2	20	N/a	18	20	22	30	30	60
3	30	N/a	20	22	24	40	40	70
4	40	N/a	N/a	24	26	50	60	90

<sup>a</sup> N/a = Not applicable.

<sup>b</sup> Gloves which, during tests, show proof test current values equal to or less than the values indicated in Table 4, will during normal use, have actual leakage current values much lower than the threshold of ventricular fibrillation. This is because the contact area with water during these tests is much greater than the contact area of the hand on the inside of the glove and the contact area of the glove with live electrical parts of equipment handled during normal use. Moreover, the proof test voltage is higher than the recommended maximum use voltage.

<sup>c</sup> For routine tests, the proof test current given by Table 4 shall be reduced by 2 mA.

<sup>d</sup> Refer to Annex D for the selection of the class of the gloves.

The proof test (see 8.4.2.1 or 8.4.3.1) is deemed successful if

- the proof test voltage is reached and maintained during the test period,
- the proof test current does not exceed the specified values during the test period. Current measurement may be done continuously or at the end of the test period.

The withstand test (see 8.4.2.2 or 8.4.3.2) is deemed successful if the voltage at which electrical puncture occurs equals or exceeds the specified withstand values.

#### 5.4 Ageing requirements

Test pieces shall be submitted to high temperature tests (see 8.5) to simulate the effects of ageing.

For dumb-bell test pieces, the lowest value of tensile strength at break shall be a value of not less than 80 % of the unaged value. The tension set shall not exceed 15 %.

Each glove shall also pass the dielectric proof test, but without being subjected to the moisture conditioning.

#### 5.5 Thermal requirements

##### 5.5.1 Low temperature resistance

No tear, break or crack shall be visible on the gloves, after being subjected to a low temperature test (see 8.6.1).

Each glove shall also pass the dielectric proof test, but without being subjected to moisture conditioning.



### **5.5.2 Flame retardancy**

Sample pieces taken from the gloves shall be flame retardant (see 8.6.2). The flame shall not have reached the reference line located on the test piece 55 mm from its edge (e.g. from the tip of the finger), within 55 s after withdrawal of the flame.

## **5.6 Gloves with special properties**

### **5.6.1 Acid resistance**

Gloves of category A shall be acid resistant (see 8.7.1). After immersion in a sulfuric acid solution, gloves shall successfully pass the following tests:

- dielectric proof test, but without moisture conditioning;
- tensile strength and elongation at break: the values obtained shall not be less than 75 % of the values obtained on gloves that have not been exposed to acid.

### **5.6.2 Oil resistance**

Gloves of category H shall be oil resistant (see 8.7.2). After immersion in a oil, gloves shall successfully pass the following tests:

- dielectric proof test, but without moisture conditioning;
- tensile strength and elongation at break: the values obtained shall not be less than 50 % of the values obtained on gloves that have not been exposed to oil.

### **5.6.3 Ozone resistance**

Gloves of category Z shall be ozone resistant (see 8.7.3). After conditioning, the gloves shall exhibit no cracks under visual inspection. Each glove shall pass the dielectric proof test, but without being subjected to moisture conditioning.

### **5.6.4 Acid, oil and ozone resistance**

Gloves of category R shall be acid, oil and ozone resistant.





### **5.6.5 Extremely low temperature resistance**

Gloves of category C shall be resistant to extremely low temperatures. No tear, break or crack shall be visible on the gloves after being subjected to an extremely low temperature test (see 8.7.4).

Each glove shall also pass the dielectric proof test, but without being subjected to moisture conditioning.

## **5.7 Marking**

Each glove which is claimed to comply with the requirements of this standard shall bear a label and/or marking giving the following information:

- symbol IEC 60417-5216 – Suitable for live working; double triangle (see Figure 5a);
-  number of the relevant European Standard immediately adjacent to the symbol with year of publication (EN 60903:2003); 
- name, trademark or identification of the manufacturer;
- category, if applicable;
- size;
- class;
-  serial number or batch number; 
- month and year of manufacture.

Composite gloves shall also be identified with a mechanical symbol (hammer), adjacent to the double triangle (see Figure 5b). The length of the hammer ( $x$ ) shall be equal to the length of one side of the triangles.

Markings and/or labels shall be adjacent to the cuff but not closer than 2,5 mm.

Markings shall be clearly visible and legible to a person with normal or corrected vision without additional magnification.

In addition, each glove shall provide the user or the testing laboratory either

- an area permitting the marking of the date of the current inspection or date of next required inspection and test, or
- any other suitable means to identify the date the glove is put into service and the dates of periodic inspection and test.

The marking or label shall not impair the quality of the glove, it shall be durable and shall remain visible after being subjected to a durability test (see 8.8).

Any additional marking or label shall be subject to agreement between the manufacturer and the customer.

When a colour code for symbols is used, it shall correspond to the following:

- class 00 – beige;
- class 0 – red;
- class 1 – white;
- class 2 – yellow;
- class 3 – green;
- class 4 – orange.

## 5.8 Packaging

Each pair of gloves shall be packaged in an individual container or package of sufficient strength to properly protect the gloves from damage. The outside of the container or package shall be marked with the name of the manufacturer or supplier, the classification, category, size, length and cuff design.

The type of packaging suitable for transport shall be defined by the manufacturer.

☐ Text deleted ☐

### ☐ 5.Z1 Manufacturer's instructions

Each pair of gloves shall come with the manufacturer's instructions for use and care.

These instructions shall include, as a minimum, the following information:

- the significance of any marking (see 5.7);
- the type of packaging suitable for transport (see 5.8);
- the classes and categories appropriate to different levels of risks and the corresponding limit of use (see Annex D);
- performance as recorded during the technical tests to check the levels or classes of protection (see Clauses 8, 9 and 10);
- the end of life deadline or period to end of life of the product; alternatively, the conditions of periodic inspection and electrical re-testing ensuring a safe use until the end of life of the product (see E.5);
- storage, use, cleaning, maintenance, servicing and disinfection. Cleaning, maintenance or disinfectant products recommended by the manufacturer and the relevant instructions;
- these gloves are intended to be used exclusively for electrical purpose. ☐

## 6 Specific mechanical requirements

### 6.1 Insulating gloves – Resistance to mechanical puncture

The average resistance to mechanical puncture shall be greater than 18 N/mm, as specified in 8.3.2.

### 6.2 Composite gloves

#### 6.2.1 Resistance to mechanical puncture

The resistance to mechanical puncture shall correspond to a force value greater than 60 N, as specified in 8.3.2.

#### 6.2.2 Abrasion resistance

The average abrasion, as obtained from the abrasion resistance test, shall be no more than 0,05 mg/r, as specified in 9.1.

#### 6.2.3 Cutting resistance

The cutting resistance shall correspond to a calculated index at least equal to 2,5, as specified in 9.2.

#### **6.2.4 Tear resistance**

The tear resistance shall correspond to an average force value greater than 25 N, as specified in 9.3.

### **7 Electrical requirements for long composite gloves**

Long composite gloves shall meet the proof test voltage requirements of 5.3 using the procedures of 8.4.

The portion of the glove up to the elbow shall meet the withstand test voltage requirements of 5.3 using the procedures of 8.4.

In addition, long composite gloves shall pass a surface leakage current test as specified in Table 5 and Clause 10.

The surface leakage test is deemed successful if:

- the test voltage is reached and maintained without flashover during the test period;
- the leakage current does not exceed the specified values at any time during the test period;
- no sign of tracking or erosion is visible on the surface.

**Table 5 – Surface leakage current test  
for long composite gloves**

Class of gloves	Test voltage kV rms	Maximum leakage current mA rms
1	10	10
2	20	10
3	30	10

## 8 General testing

### 8.1 General

Each of the following subclauses defines whether type, routine or sampling tests are required.

Gloves which have been subjected to type tests or sampling tests should not be reused.

The allotment of these gloves into various testing lots, the quantity required and the order in which these tests are carried out are given in Annex A. The gloves used in the visual tests shall also be used in one of the other tests.

Gloves shall be preconditioned for a period of  $2\text{ h} \pm 0,5\text{ h}$  at a temperature of  $23\text{ °C} \pm 2\text{ °C}$  and  $50\% \pm 5\%$  relative humidity (see IEC 60212, standard atmosphere B), except for gloves to be tested for water absorption as part of the type or sampling tests; these gloves shall be conditioned in accordance with 8.4.1.

### 8.2 Visual inspection and measurements

Visual inspection shall be carried out by a person with normal or corrected vision without additional magnification.

#### 8.2.1 Shape

Type test and sampling test (see 5.1.2 and Figures 1 and 2)

The shape of the glove shall be verified by visual inspection.

#### 8.2.2 Dimensions

Type test and sampling test (see 5.1.3, Figures 1, 2, 3 and Annex F)

The length of the glove shall be measured from the tip of the second finger to the outer edge of the cuff. The measurement is made with the glove in a relaxed position and the edge of the cuff perpendicular to the line of measurement.

The difference in length for contour-cuff gloves shall be measured with the glove in the relaxed position, along a line parallel to the length dimension, as shown in Figure 3.

### **8.2.3 Thickness**

Type test and sampling test (see 5.1.4)

Thickness measurements shall be made on one complete glove as follows:

- at four or more points on the palm of the glove;
- at four or more points on the back of the glove but not on the cuff;
- at one or more points on the thumb and on the index finger in the “finger print” area.

Such points shall be distributed over the surface and not concentrated. They shall not be distributed on parts of the surface especially designed to improve the grip.

Measurements shall be made with a micrometer or any alternative instrument giving substantially the same results. The micrometer shall be graduated to within 0,02 mm and have an anvil of about 6 mm in diameter and a flat presser foot  $3,17 \text{ mm} \pm 0,25 \text{ mm}$  in diameter. The presser foot shall exert a total force of  $0,83 \text{ N} \pm 0,03 \text{ N}$ . Sufficient support shall be given to the glove so that it presents an unstressed, flat surface between the anvil faces of the micrometer.

In case of dispute, the micrometer method described above shall be used.

### **8.2.4 Workmanship and finish**

Type test and sampling test (see 5.1.5)

The workmanship and finish shall be verified by visual inspection.

## **8.3 Mechanical tests**

In the case of lined gloves, special unlined gloves shall be provided by the manufacturer in order to carry out the tensile strength test and the tension set test.

### **8.3.1 Tensile strength and elongation at break**

Type test and sampling test

Four test pieces having the dumb-bell outline shown in Figure 6 shall be cut from each glove under test; one from the palm, one from the back and two from the wrist area (see ISO 37).

Reference lines, 20 mm apart, shall be marked on these test pieces, symmetrically placed on the narrow part of the dumb-bell (see Figure 6).

The test pieces shall be tested in a tensile testing machine which shall be power driven at a sufficient speed to maintain the rate of traverse of the driven grip substantially constant up to the maximum force capacity of the machine. The rate of traverse shall be  $500 \text{ mm/min} \pm 50 \text{ mm/min}$ .

The tensile strength shall be calculated by dividing the force at break by the initial area of the cross section under test.

NOTE 1 The machine should be equipped to give a continuous indication of the force applied to the test piece and a graduated scale to measure the elongation.

NOTE 2 After the test piece has been broken, the machine should give a permanent indication of the maximum force and, where possible, the maximum elongation.

### 8.3.2 Resistance to mechanical puncture

#### Type test and sampling test

Two circular test pieces 50 mm in diameter shall be cut from the glove and each shall be clamped between two flat test plates of 50 mm diameter. The top plate shall have a circular opening of 6 mm in diameter and the bottom plate a 25 mm diameter circular opening. The edges of both openings shall be rounded to a radius of 0,8 mm (see Figure 7).

A needle shall be made from a 5 mm diameter metallic rod and one end shall be machined to produce a taper having an angle of 12° and with the tip rounded to a radius of 0,8 mm (see Figure 7). The needle shall be clean at time of use.

The needle shall be positioned perpendicularly above the test piece (clamped between the plates) and shall be driven into and through the test piece. The rate of traverse shall be 500 mm/min ± 10 mm/min. The force required to puncture the test piece shall be measured.

### 8.3.3 Tension set

#### Type test and sampling test

Three test pieces, having the outline shown in Figure 6, shall be cut from each glove under test, one from the palm, one from the back and one from the wrist. The test pieces shall be fitted in a straining device consisting of a metal rod or other suitable guide fitted with a pair of holders, one fixed and one movable, to hold the ends of the test piece.

The measurement of the unstrained reference length (shown as  $l_0$  in Figure 6) shall be checked to the nearest 0,1 mm and the test piece shall be placed in the holder. The test piece shall be extended at a speed of between 2 mm/s and 10 mm/s to a 400 % ± 10 % elongation and held for 10 min. After this time, the strain shall be released at a speed of between 2 mm/s and 10 mm/s, and then the test piece shall be removed from the holder and laid free on a flat surface. After a 10 min recovery time, the reference length shall be measured again.

The tension set is calculated as a percentage of the initial strain as follows:

$$\text{Tension set} = 100 \frac{l_1 - l_0}{l_s - l_0}$$

where

$l_0$  is the original unstrained reference length;

$l_s$  is the strained reference length;

$l_1$  is the reference length after recovery.

## **8.4 Dielectric tests**

### **8.4.1 General**

Dielectric testing shall be carried out either with a.c. or d.c. voltage and at a temperature of  $23\text{ °C} \pm 5\text{ °C}$  and 45 % to 75 % relative humidity (see IEC 60212). The choice of a.c. or d.c. shall be made after agreement between manufacturer and customer.

For type and sampling tests, the gloves shall be given an a.c. proof current test after conditioning for moisture absorption by total immersion in water for a period of  $16\text{ h} \pm 0,5\text{ h}$ . The immersion shall be carried out without trapping air. The a.c. dielectric tests shall be conducted within 1 h after completion of conditioning. Such conditioning is not required for routine a.c. proof current tests.

The peak (crest) or r.m.s. value of the a.c. voltage and the arithmetic mean value of the d.c. voltage shall be measured with an error of not more than 3 % (see IEC 60060-2).

#### **8.4.1.1 General test procedure**

After conditioning, if conditioning is necessary, the gloves, right side out, shall be filled with tap water having a specific resistivity less than or equal to  $100\ \Omega\cdot\text{m}$ , and immersed in a tank of water to a depth in accordance with Table 6. The water level during the test shall be the same inside and outside the glove.

For the routine test on certain types of gloves (e.g. lined) where the water would be injurious to the inside surface, nickel stainless steel metal balls 4 mm, in diameter, can be used in place of water. The water inside the glove that forms one electrode shall be connected to one terminal of the voltage source by means of a chain or sliding rod that dips into the water. The water in the tank outside the glove that forms the other electrode shall be connected directly to the other terminal of the voltage source. The water shall be free of air bubbles and air pockets and the exposed portion of the glove above the water line shall be dry.

The test equipment used in both the proof and withstand tests shall be capable of supplying an essentially stepless and continuously variable voltage to the item under test. Motor-driven regulating equipment is convenient and tends to provide uniform rate of rise to the test voltage. The test apparatus shall be protected by an automatic circuit-breaking device designed to open promptly on the current produced by failure of an item under test. This circuit-breaking device shall be designed to protect the test equipment under any conditions of short circuit.

NOTE 1 It is recommended that the testing equipment system be inspected and calibrated at least annually to ensure that the general condition of the equipment is acceptable, and to verify the characteristics and accuracy of the test voltage.

NOTE 2 To eliminate damaging ozone and possible flashover along the cuff, there should be a sufficient flow of air into and around the glove and an exhaust system to adequately remove ozone from the test machine. Consistent ozone checking during the test procedure should be carried out to ascertain the adequacy of the exhaust system.

For long composite gloves, the clearance between the open part of the glove and the water line shall be  $400\text{ mm} \pm 13\text{ mm}$ .



For all the other gloves, the clearance between the open part of the glove and the water line is given in Table 6.

**Table 6 – Clearance from open part of the glove to water line**

Class of gloves	Clearance for tests <i>D</i> mm			
	AC		DC	
	Proof test	Withstand test	Proof test	Withstand test
00	40	40	40	50
0	40	40	40	50
1	40	65	50	100
2	65	75	75	130
3	90	100	100	150
4	130	165	150	180

NOTE 1 See Figure 8 for open part of the glove to water line distance ( $D_1$  or  $D_2$  dependent on gauntlet shape).

NOTE 2 Permissible tolerance for the clearance between the open part of the glove and water line is  $\pm 13$  mm.

NOTE 3 Where high humidity (above 55 %) or low barometric pressure (below 99,3 kPa) is encountered, the specified clearances may be increased by a maximum of 25 mm.

#### 8.4.1.2 Failure indicators

Glove failure indicators or accessory circuits shall be designed to give positive indication of failure.

#### 8.4.2 AC test procedure

The test equipment shall comply with IEC 60060-1.

The proof test current is measured directly by inserting a milliammeter in series with each individual glove in turn. The reading should be taken towards the end of the proof test voltage period.

NOTE 1 It is customary to make this type of high-voltage test with one end of the circuit grounded. When proof current tests are made on one glove at a time, the water in the tank is usually connected to the grounded end of the high-voltage circuit. The milliammeter is connected in the grounded end of the circuit and shunted by a short-circuiting, automatic self-closing switch which keeps the circuit closed except at the instant of reading and thus maintains an uninterrupted ground.

NOTE 2 When proof current tests are made on more than one glove at one time, the water in the tank should be at high potential if it is required that the water electrodes inside the gloves be the grounded electrodes. The ammeter for reading proof test current is then connected to the ground electrode through a suitable switching arrangement to permit reading of the proof test current in each glove separately.

NOTE 3 If ammeter and switching arrangements are suitably insulated, they may be used in the high-voltage circuit of the gloves, and the water in the tank may be grounded.

#### **8.4.2.1 AC proof test**

Type test, sampling test and routine test

Each glove shall be submitted to a proof voltage test as specified in Table 4. The a.c. voltage shall be initially applied at a low value and gradually increased at a constant rate-of-rise of approximately 1 000 V/s until the specified test voltage level is reached or failure occurs. The current is measured during test period, either continuously or at end of period. The test voltage shall be reduced at the same rate. The test period shall be equal to 3 min for the type and sampling tests and 1 min for the routine test, considered to start at the instant the specified proof voltage is reached.

NOTE At the end of the test period, the applied voltage should be reduced to half value before opening the test circuit, unless an electrical failure has already occurred.

#### **8.4.2.2 AC withstand test**

Type test and sampling test

The a.c. voltage shall be applied as specified in 8.4.2.1 until the specified withstand voltage is reached, then reduced.

If an electrical puncture occurs, the maximum voltage observed prior to failure shall be considered as the withstand voltage.

#### **8.4.3 DC test procedure**

The d.c. test voltage shall be obtained from a d.c. source capable of supplying the required voltage. The ripple component of the d.c. test voltage when applied to the test piece shall not exceed 5 % of the average value (see IEC 60060-1).

The d.c. proof test voltage shall be measured by a method that provides the average value of the voltage applied to the glove. It is recommended that the voltage be measured by the use of a d.c. meter connected in series with appropriate high-voltage type resistors across the high-voltage circuit. An electrostatic voltmeter of proper range may be used in place of the d.c. meter resistor combination.

#### **8.4.3.1 DC proof test**

Type test, sampling test and routine test

Each glove shall be given a proof voltage test as specified in Table 4. This voltage shall be initially applied at a low value and gradually increased at a constant rate-of-rise of approximately 3 000 V/s until the specified test voltage level is reached or failure occurs. It shall then be reduced at the same rate. The test period shall be equal to 3 min for the type and sampling tests and 1 min for the routine test, considered to start at the instant the specified proof voltage is reached.

NOTE At the end of the test period, the applied voltage should be reduced to half-value before opening the test circuit, unless an electrical failure has already occurred.

#### 8.4.3.2 DC withstand test

Type test and sampling test

The d.c. voltage shall be applied as specified in 8.4.3.1 until the specified withstand voltage is reached, then reduced.

If an electrical puncture occurs, the maximum voltage observed prior to failure shall be considered the withstand voltage.

#### 8.5 Ageing test

Type test and sampling test

Four dumb-bell test pieces shall be cut as shown in 8.3.1 and three pieces as shown in 8.3.3.

The test pieces, along with two gloves, shall be placed in an air oven for 168 h at  $70\text{ °C} \pm 2\text{ °C}$  and with less than 20 % relative humidity (see IEC 60212).

The apparatus shall consist of an air oven in which there is a circulation of air providing between 3 to 10 changes per hour. The incoming air shall be at  $70\text{ °C} \pm 2\text{ °C}$  before coming in contact with the test pieces.

There shall be no copper or copper alloy parts inside the ageing chamber. Provision shall be made for suspending the test pieces so that there is a minimum separation of 10 mm between the test pieces and of 50 mm between the test pieces and the inner surfaces of the oven.

At the end of the heating period, the test pieces shall be removed from the oven and allowed to cool for not less than 24 h and then tested.

#### 8.6 Thermal tests

##### 8.6.1 Low temperature test

Type test and sampling test

Three gloves shall be placed in a chamber for 1 h at a temperature of  $-25\text{ °C} \pm 3\text{ °C}$ . Two polyethylene plates  $200\text{ mm} \times 200\text{ mm} \times 5\text{ mm}$  thick shall be conditioned at the same temperature and for the same time.

Within 1 min after being removed from the chamber, the gloves shall be folded at the wrist (see Figure 9), placed between the two polyethylene plates and subjected to a force of 100 N for 30 s as shown in Figure 10.

##### 8.6.2 Flame retardancy test

Type test and sampling test

The second or third finger of a glove or the finger of a mitt shall be cut to a length of 60 mm to 70 mm, filled with plaster of Paris and mounted on a steel shaft 5 mm in diameter and 120 mm long. The shaft shall be centered on the interior of the finger and inserted to approximately midpoint. The test piece shall be allowed to harden for at least 24 h.

The test shall be carried out in a draught-free room. The test piece shall be clamped as indicated in Figure 11. For the purpose of the test, a small burner shall be arranged in a vertical position below the test piece, its axis being 5 mm within the extremity of the test piece.

The gas supply shall be technical grade methane gas with a suitable regulator and meter to produce a uniform gas flow.

NOTE If natural gas is used as an alternative to methane, its heat content should be approximately 37 MJ/m<sup>3</sup> which has been found to provide similar results.

The nozzle of the burner shall have a diameter of 9,5 mm ± 0,5 mm in order to produce a 20 mm ± 2 mm high blue flame.

The burner is placed away from the test piece, ignited and adjusted in the vertical position to produce a blue flame 20 mm ± 2 mm high. The flame is obtained by adjusting the gas supply and the air ports of the burner until a 20 mm ± 2 mm yellow tipped blue flame is produced. The air supply is then increased until the yellow tip disappears. The height of the flame is measured again and corrected if necessary.

The burner shall then be placed in the test position as shown in Figure 11.

The flame shall be applied to the test piece for 10 s. After this period, the testing flame shall be withdrawn. It should be ensured that no air draught interferes with the test.

The propagation of the flame on the test piece shall be observed for 55 s after the withdrawal of the testing flame.

## **8.7 Tests on gloves with special properties**

### **8.7.1 Category A – Acid resistance**

Type test and sampling test

The gloves of category A shall be conditioned by immersing in 32 °B sulphuric acid solution at a temperature of 23 °C ± 2 °C for 8 h ± 0,5 h. Only the outer surface of the glove shall be exposed to the solution. Following acid conditioning, the glove shall be rinsed in water and dried for 2 h ± 0,5 h at approximately 70 °C.

The time elapsed between end of drying and start of testing shall be 45 min ± 5 min.

### **8.7.2 Category H – Oil resistance**

Type test and sampling test

The gloves of category H shall be preconditioned in air for not less than 3 h ± 0,5 h at 23 °C ± 2 °C and at 50 % ± 5 % relative humidity and then conditioned by immersion in liquid 102 (see Annex B) at a temperature of 70 °C ± 2 °C for 24 h ± 0,5 h. Only the outer surface of the glove shall be exposed to the liquid.

Following oil conditioning, the glove shall be dried using a lint-free clean absorbent cloth.

The time elapsed between removal from liquid and start of testing shall be 45 min ± 15 min.

### 8.7.3 Category Z – Ozone resistance

Type test and sampling test

The gloves of category Z shall be conditioned in an oven for  $3 \text{ h} \pm 0,5 \text{ h}$  at a temperature of  $40 \text{ }^\circ\text{C} \pm 2 \text{ }^\circ\text{C}$ , and an ozone concentration of  $1 \text{ mg/m}^3 \pm 0,01 \text{ mg/m}^3$  ( $0,5 \times 10^{-6} \pm 0,05 \times 10^{-6}$  by volume) at standard atmospheric pressure of 1 013 mbar (101,3 kPa).

The gloves shall then be stored at a room temperature of  $23 \text{ }^\circ\text{C} \pm 2 \text{ }^\circ\text{C}$ , and  $50 \% \pm 5 \%$  relative humidity for  $48 \text{ h} \pm 0,5 \text{ h}$  and then examined for ozone damage.

### 8.7.4 Category C – Extremely low temperature resistance

Type test and sampling test

Three gloves of category C shall be placed in a chamber for  $24 \text{ h} \pm 0,5 \text{ h}$  at a temperature of  $-40 \text{ }^\circ\text{C} \pm 3 \text{ }^\circ\text{C}$ . Two polyethylene plates  $200 \text{ mm} \times 200 \text{ mm} \times 5 \text{ mm}$  thick shall be conditioned at the same temperature and for the same time.

Within 1 min after removal from the chamber, the gloves shall be folded at the wrist (see Figure 9), placed between the two polyethylene plates and subjected to a force of 100 N for 30 s as shown in Figure 10.

## 8.8 Marking

Type test and routine test

Compliance with the requirements of 5.7 shall be verified by visual inspection.

The durability of marking shall be checked by rubbing the marking for 15 s with a piece of lint-free cloth soaked in soapy water and then rubbing it for a further 15 s with a piece of lint-free cloth soaked in isopropanol. At the end of the test the marking shall remain legible.

No durability test is required for the routine test.

## 8.9 Packaging

Type test and sampling test

Compliance with the requirements of 5.8 shall be verified by visual inspection.

## 9 Specific mechanical testing

### 9.1 Abrasion resistance

Type test and sampling test

The abrasion resistance tester (see Figure 12) consists of a test piece holder which rotates around a central axis at a speed of  $60 \text{ r/min} \pm 5 \text{ r/min}$ . The test piece is secured onto the disk by means of a fixing ring.

Two abrasive rings made of tungsten carbide are placed onto two wheels 13 mm wide and 52 mm in diameter, the inner sides of which are 52 mm  $\pm$  1 mm far one from the other. A brush and vacuum suction eliminates the particles coming from the test piece being tested.

The surface of the test piece is cleaned with dry compressed air at 200 kPa  $\pm$  35 kPa. The two abrasive wheels are fixed at the free end of oscillating arms and are in contact with the upper surface of the test piece.

The rotation of the wheels in opposite directions is obtained by the rotation of the test piece changing the friction axis.

The test piece shall consist of a plate 114 mm in diameter with a central hole 6 mm in diameter. The test piece shall be cut from the glove in the palm or wrist area.

Five gloves shall be subjected to the test. The abrasive rings are of type S 35.

The vertical force of each wheel onto the test piece is 2,45 N.

The result is given in mg/r in accordance with the following formula:

$$\frac{m_0 - m_1}{n}$$

where

$m_0$  is the initial weight of the test piece in mg;

$m_1$  is the weight of the test piece after test in mg;

$n$  is the number of revolutions.

## 9.2 Cutting resistance

Type test and sampling test

The test equipment (see Figure 13) consists of:

- a test bench providing a backwards and forwards horizontal movement against a circular, rotating blade. The horizontal movement is 50 mm long and the knife rotates completely in the opposite direction to that of the test bench. The resulting sinusoidal cutting speed of the blade is a maximum of 10 cm/s;
- a mass applied to the blade to produce a force of 5 N;
- a circular blade with a diameter of 45 mm, a thickness of 0,3 mm and a total angle of 30° to 35° (see Figure 13). The blade shall be in tungsten with an HV (Vickers hardness) of 740-800;
- a support of conductive rubber (hardness 80 IHRD  $\pm$  3 IHRD) on which the test piece is placed;
- a clamping frame for the test piece as described in Figure 13;
- an automatic system to detect the movement of cut-through;
- a cycle counter calibrated to one-tenth (1/10) of a cycle.

NOTE Cotton canvas additional characteristics and additional information on cutting resistance test equipment are given in Annex G.

The test shall be carried out on both reference test pieces and test pieces cut from gloves.

### 9.2.1 Test on reference test piece

The reference test piece shall be cut from a cotton canvas according to the following technical specifications (see Annex G):

- fabric warp and weft: cotton spun from open end fibres;
- linear mass warp and weft: 161 Tex;
- twist warp: double twist **s** 280 t/m, single yarn **z** 500 t/m;
- twist weft: same as warp;
- warp: 18 threads per cm;
- weft: 11 threads per cm;
- crimp warp: 29 %;
- crimp weft: 4 %;
- tensile strength in warp: 1 400 N;
- tensile strength in weft: 1 000 N;
- mass per unit area: 540 g/m<sup>2</sup>;
- thickness: 1,2 mm;
- dimensions: 80 mm × 100 mm.

The reference test piece shall be cut on the bias to the warp.

A layer of aluminium foil is placed on the rubber support. The reference test piece is placed without stretching on top of the foil within the clamping frame. The clamping frame is positioned on the table. The arm holding the blade is lowered onto the reference test piece.

The sharpness of the blade is checked as follows.

The cut-through is indicated by a light or sound signal. The number of cycles (*C*) is recorded. The number of cycles shall be between 1 and 4 if the expected performance level is less than 3 and between 1 and 2 if the performance level is equal or more than 3.

### 9.2.2 Test on glove test piece

Two glove test pieces of the same dimensions shall be cut from the palms of two different gloves.

Each glove test piece shall be subjected to the same test as described above and the number of cycles (*T*) recorded.

Five tests shall be made on each glove test piece according to the following sequence for each test:

- 1) test on the reference test piece;
- 2) test on the glove test piece;
- 3) test on the reference test piece.

The results are presented as in Table 7.

**Table 7 – Presentation of test results on glove test piece**

Test number	Sequence			
	Reference test piece	Glove test piece	Reference test piece	<i>i</i> index
1	$C_1$	$T_1$	$C_2$	$i_1$
2	$C_2$	$T_2$	$C_3$	$i_2$
3	$C_3$	$T_3$	$C_4$	$i_3$
4	$C_4$	$T_4$	$C_5$	$i_4$
5	$C_5$	$T_5$	$C_6$	$i_5$

where

$$I = \frac{1}{5} \sum_{n=1}^{n=5} i_n \quad \text{and} \quad i_n = \frac{\bar{C}_n - T_n}{C_n}$$

$$\text{with} \quad \bar{C}_n = \frac{C_n + C_{n+1}}{2}$$

$\bar{C}_n$  represents the average value of cycles on the reference test piece before and after the cut of glove test piece  $T_n$ .

### 9.3 Tear resistance

Type test and sampling test

Only tensile testers equipped with low inertia force measurement systems shall be used.

The tear resistance is defined as the force necessary to tear a test piece which was previously cut in a defined manner.

Two test pieces shall be tested in the direction of the glove from cuff to finger tips, and two test pieces shall be tested across the palm width (see Figure 14).

The dimensions of the test piece are 100 mm × 50 mm. A 50 mm incision is made in the longitudinal direction of the test piece, 25 mm from the edge, as illustrated in Figure 15. The last millimetre of the incision shall be made with a sharp, unused blade straight and perpendicular to the test piece surface.

The 20 mm of each pre-cut defined strip (see Figure 15) are clamped in a tensile tester with the jaws 50 mm apart such as to guarantee a pulling direction in the plane parallel to the longitudinal direction of the test piece.

The testing force shall be recorded on an X-Y recorder at a tensile test speed of 100 mm/min ± 10 mm/min.

The test piece shall be totally torn apart. In some cases the tearing may not be in the longitudinal direction of the test piece.



The test shall be performed on one test piece cut from each of four different gloves of the same glove series.

The tear resistance for each test piece is recorded at the highest peak value.

## 10 Leakage current test

Type test and sampling test

This test is applicable only to long composite gloves.

### 10.1 General test conditions

The test location shall be at the standard atmospheric conditions as stated in IEC 60212 and the water temperature shall be within the same limits as the ambient temperature, i.e. 18 °C to 28 °C.

Before testing, each glove shall be prepared by cleaning with isopropanol and then dried in air for 15 min.

The tests shall be carried out on three gloves of the same class.

Wet conditions shall be in accordance with the procedure described in IEC 60060-1, e.g.:

- average precipitation rate: 1 mm/min to 2 mm/min;
- resistivity of collected water corrected to 20 °C:  $(100 \pm 15) \Omega\text{m}$ .

### 10.2 Test arrangement

The test arrangement is shown in Figure 16. The glove is inclined fully extended, at an angle of 45° and with its palm turned upwards.

The palm area of the glove is put in contact with a cylindrical conductor having a diameter of  $12 \text{ mm} \pm 2 \text{ mm}$ .

The open part of the glove is wrapped in close contact around a cylindrical electrode, as indicated in Figure 16.

The high-voltage terminal of the a.c. source is connected to the cylindrical conductor in the palm, and the grounded terminal is connected to the cylindrical electrode.

The incident angle between the rain and the axis of the glove shall be approximately 90°.

### **10.3 Test procedure**

The test equipment shall comply with the conditions set out in IEC 60060-1.

The leakage current is measured directly by inserting a milliammeter in series with the cylindrical electrode. The reading should be taken towards the end of the test period.

Each glove shall be submitted to a leakage current test as specified in Table 5.

The a.c. voltage shall be initially applied at a low value and gradually increased at a constant rate of rise of approximately 1 000 V/s, until the specified test voltage is reached or failure occurs.

The test period shall be 3 min, considered to start at the instant the specified test voltage is reached.

The test voltage shall be reduced at the same rate.

NOTE At the end of the test period, the applied voltage should be reduced to half value before opening the test circuit unless an electrical failure has already occurred.

## **11 Quality assurance plan and acceptance tests**

### **11.1 General**

In order to assure the delivery of gloves that meet this standard, the manufacturer shall employ an approved quality assurance plan that complies with the provisions of the ISO 9000 series.

The quality assurance plan shall ascertain that the gloves meet the requirements of this standard.

In the absence of an accepted quality assurance plan as specified above, the sampling procedure detailed in Annex C shall be carried out.

### **11.2 Categories of tests**

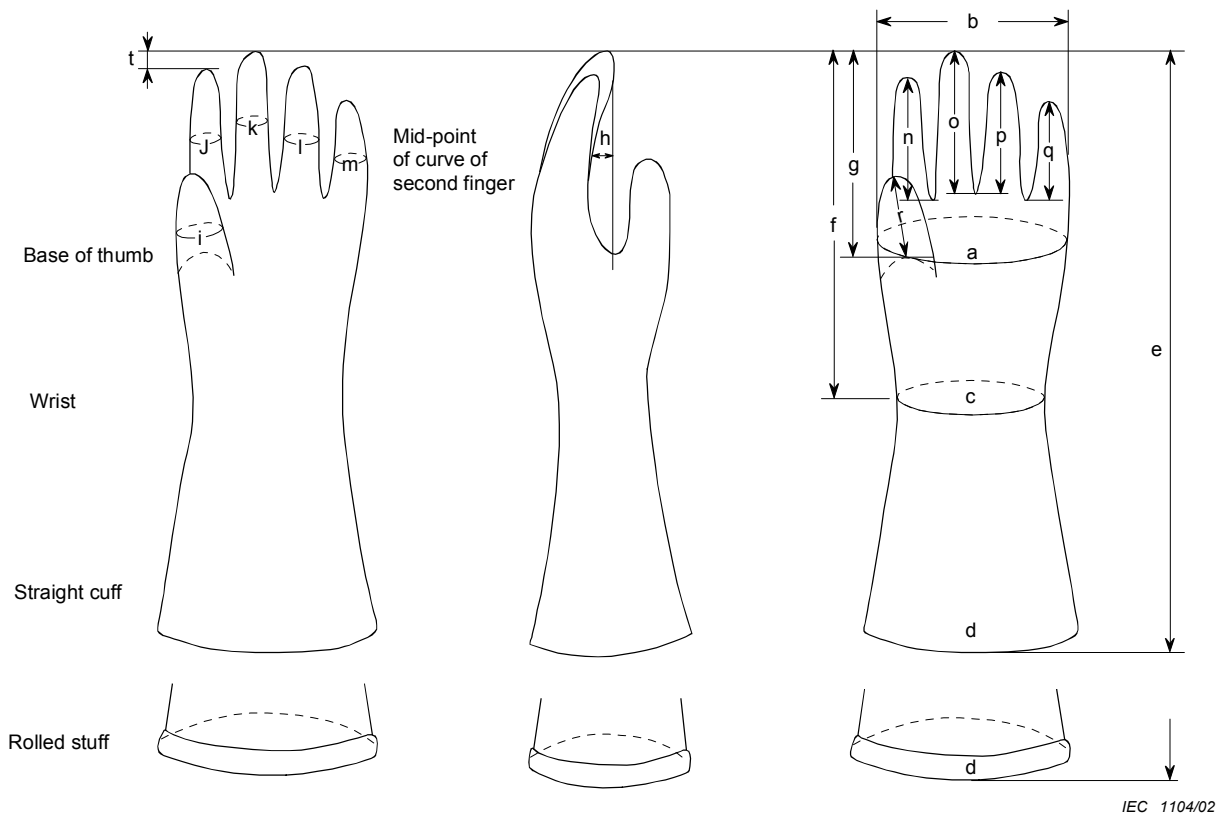
There are four categories of tests: type, routine, sampling and acceptance. These are defined in Clause 3.

### **11.3 Sampling procedure**

The sampling procedure shall be in accordance with the type test and as specified in Annex C.

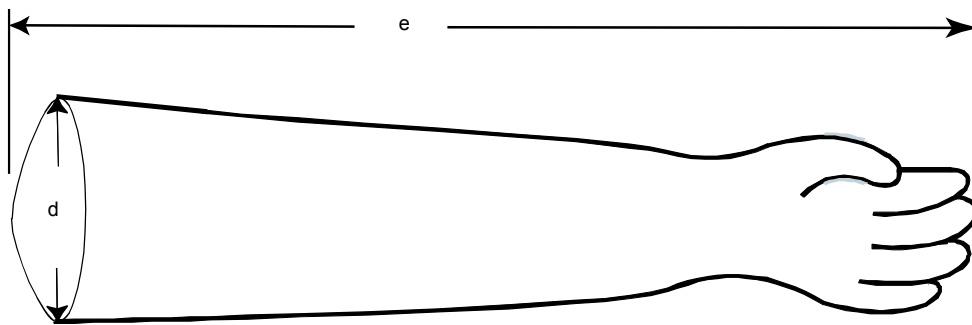
### **11.4 Acceptance tests**

Acceptance test results shall be available to the customer according to the customer requirements or for at least two years (see Annex H).



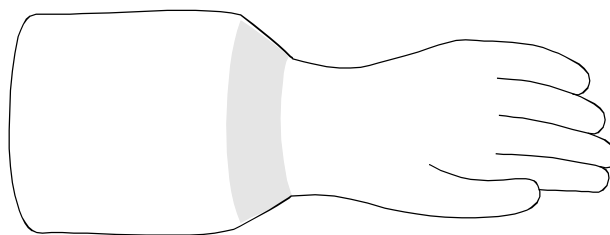
NOTE Letters a, b, etc. are fully explained in Table F.1

**Figure 1a – Shape of a glove**



IEC 1105/02

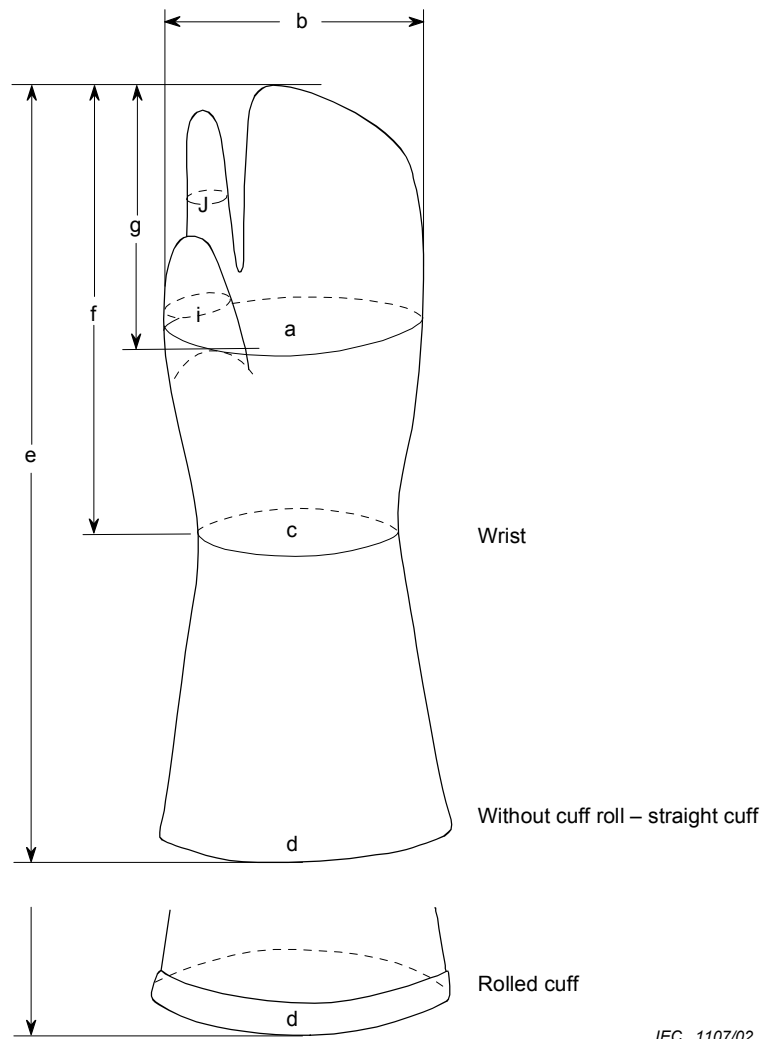
**Figure 1b – Shape of a long composite glove**



IEC 1106/02

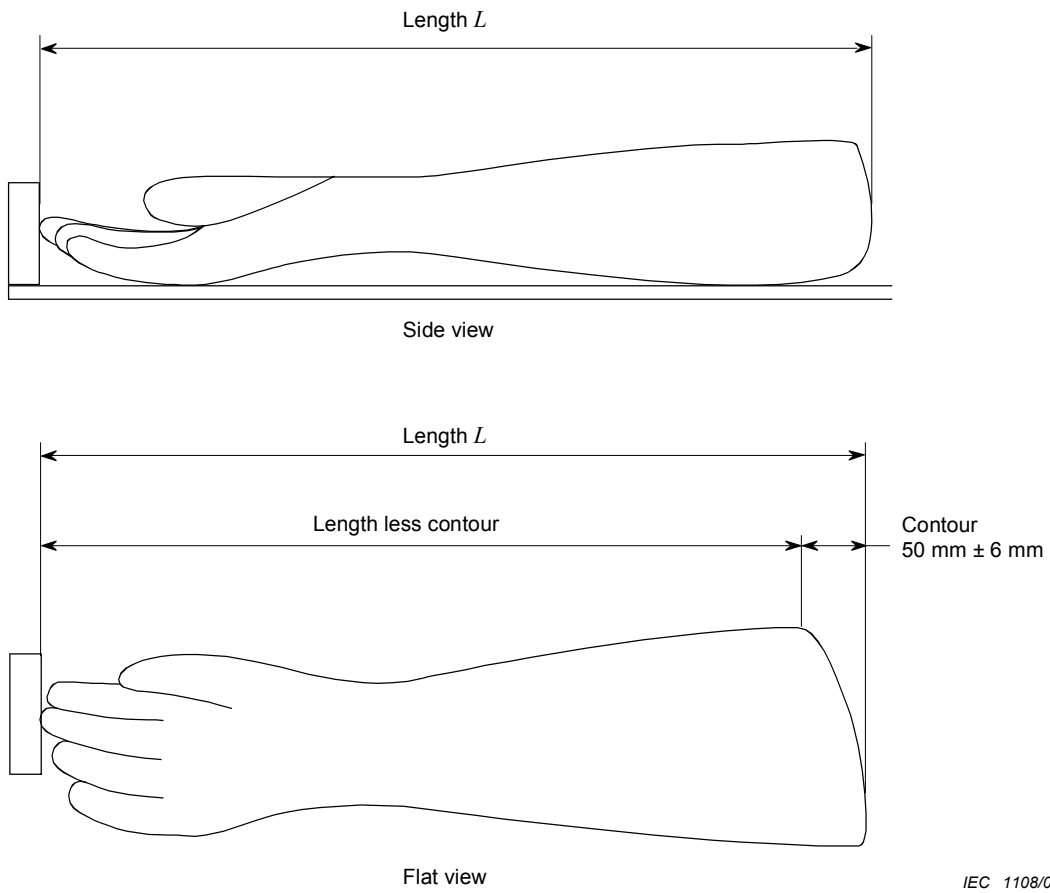
**Figure 1c – Shape of a bell cuff glove**

**Figure 1 – Examples of typical shapes of gloves**



NOTE Dimensions a, b, c, d, e, f, g, i, j, n and r are the same as for gloves (see Figure 1a).

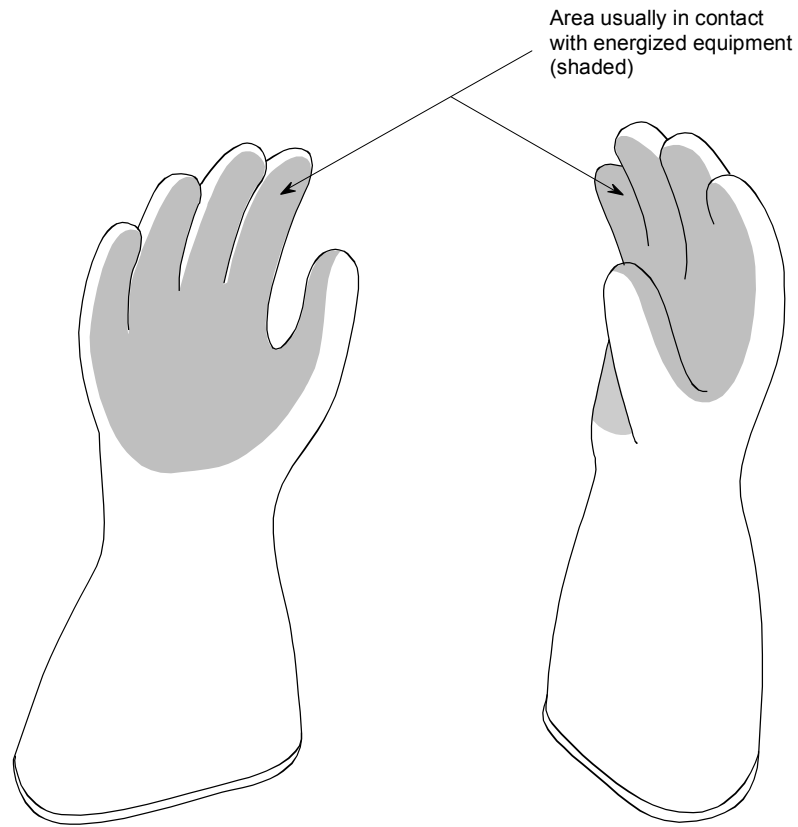
**Figure 2 – Shape of mitts**



NOTE Gloves can have either rolled or straight cuff.

**Figure 3 – Contour of glove (see 8.2.2)**

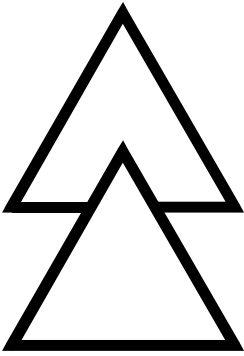
IEC 1108/02



IEC 1109/02

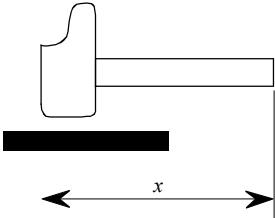
NOTE In normal use, the total area in contact with energized parts is such that the current in hand should not exceed 1 mA.

**Figure 4 – Example of area usually in contact with energized equipment**



IEC 1110/02

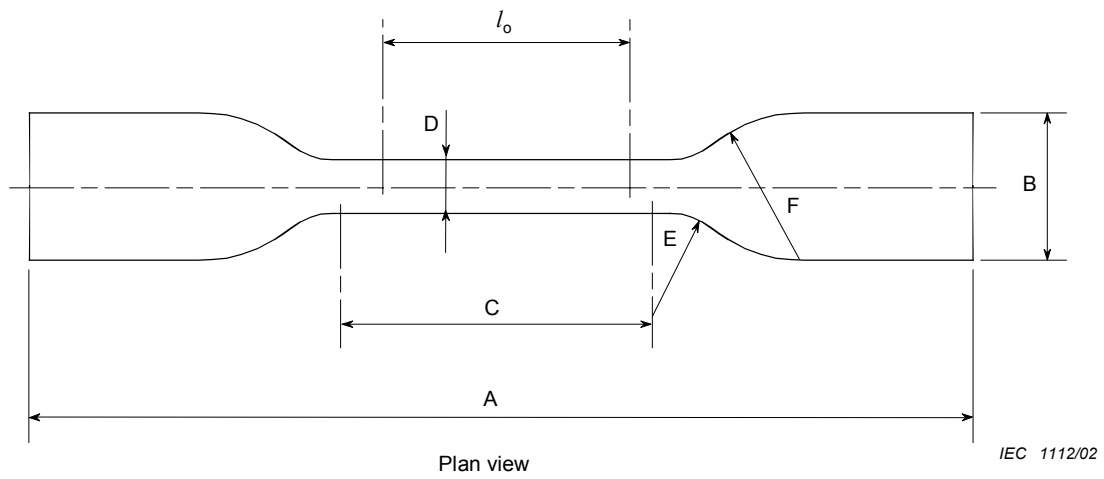
Figure 5a – Symbol IEC 60417-5216 – Suitable for live working; double triangle



IEC 1111/02

Figure 5b – Composite glove symbol – Hammer

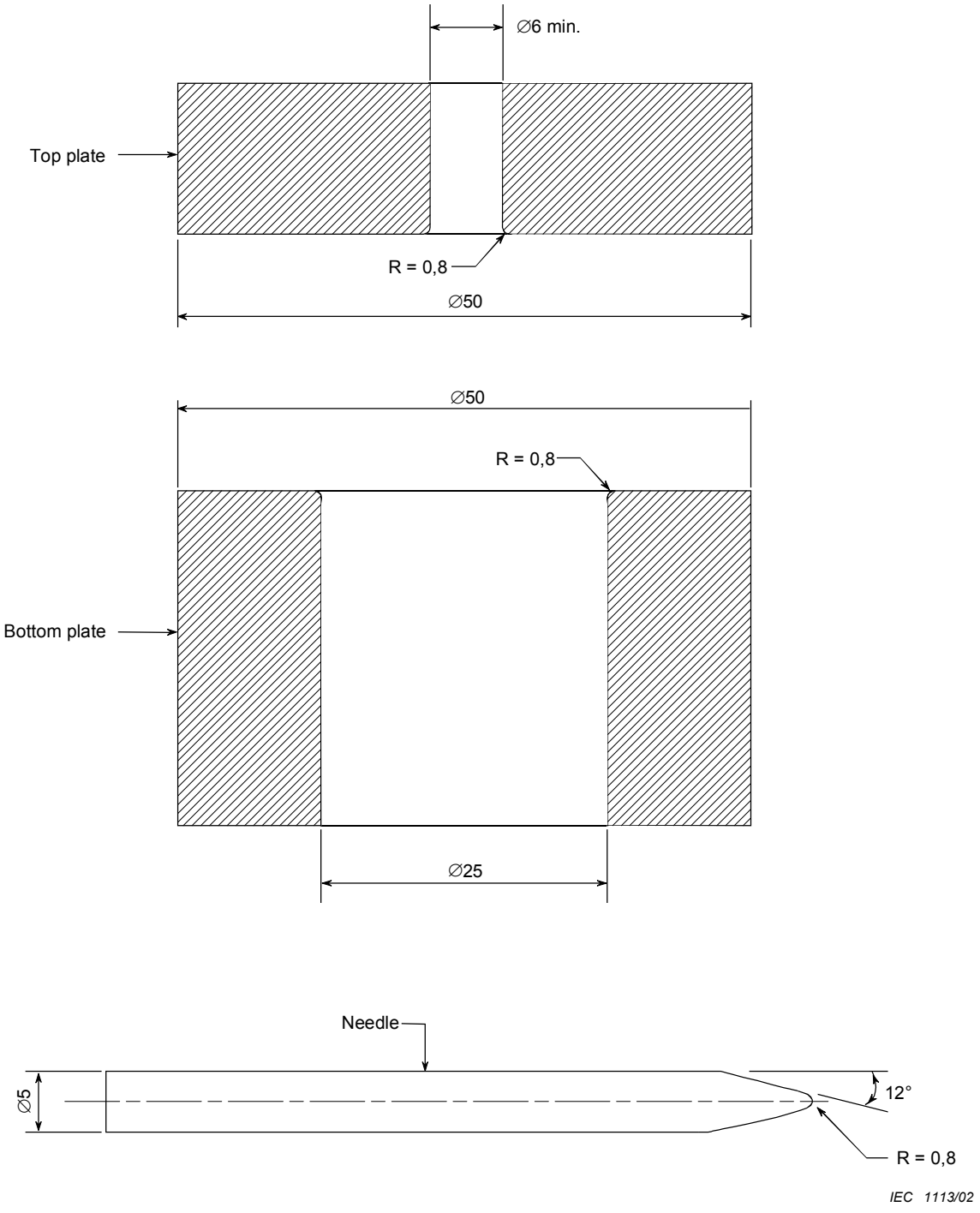
Figure 5 – Marking symbols (see 5.7)



Reference	Dimensions mm
A	75
B	$12,5 \pm 1,0$
C	$25 \pm 1$
D	$4 \pm 0,1$
E	$8 \pm 0,5$
F	$12,5 \pm 1$
$l_0$	20

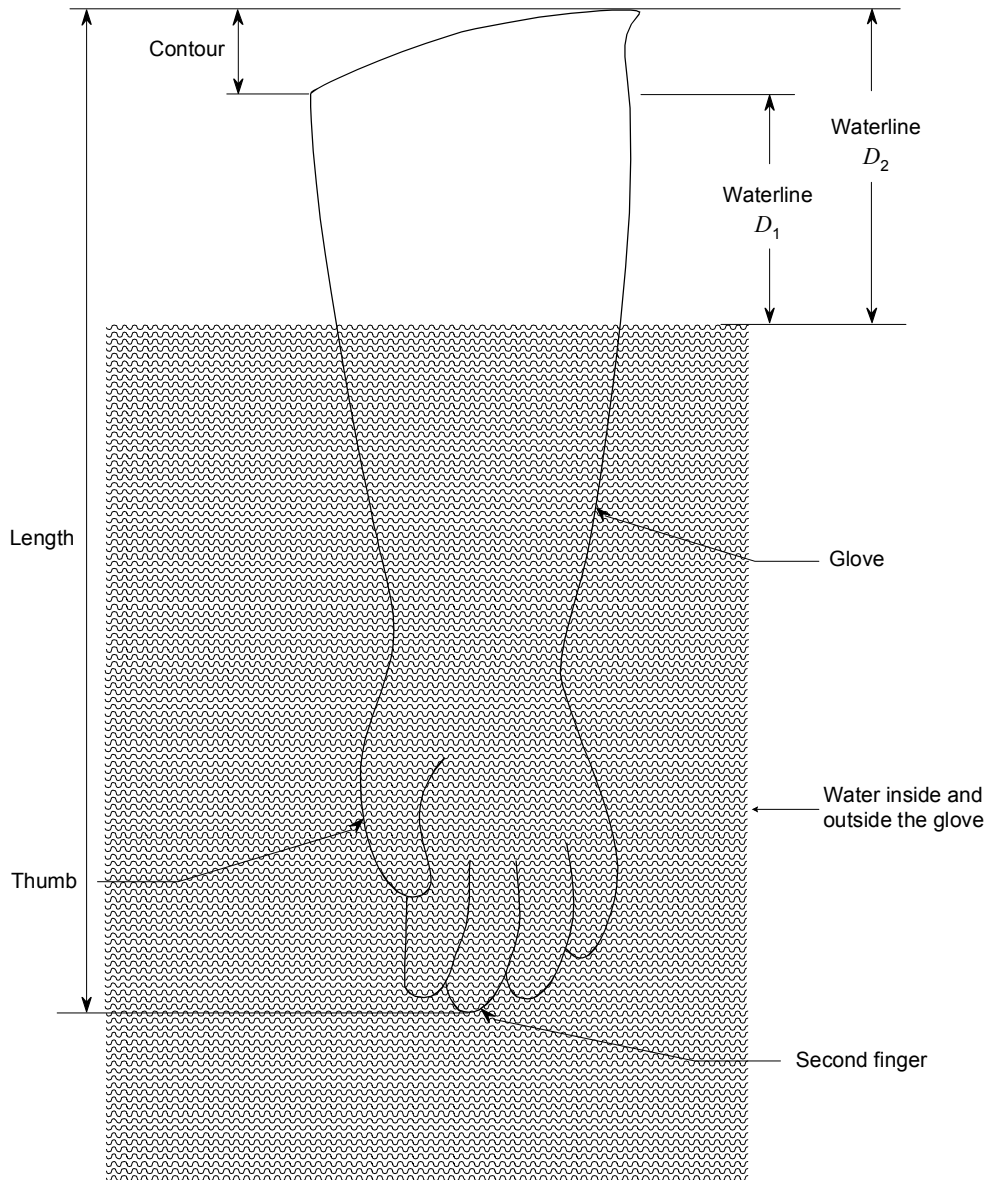
**Figure 6 – Dumb-bell test piece for mechanical tests  
(see 8.3.1, 8.3.3 and 18.5)**





Dimensions in millimetres except for angles

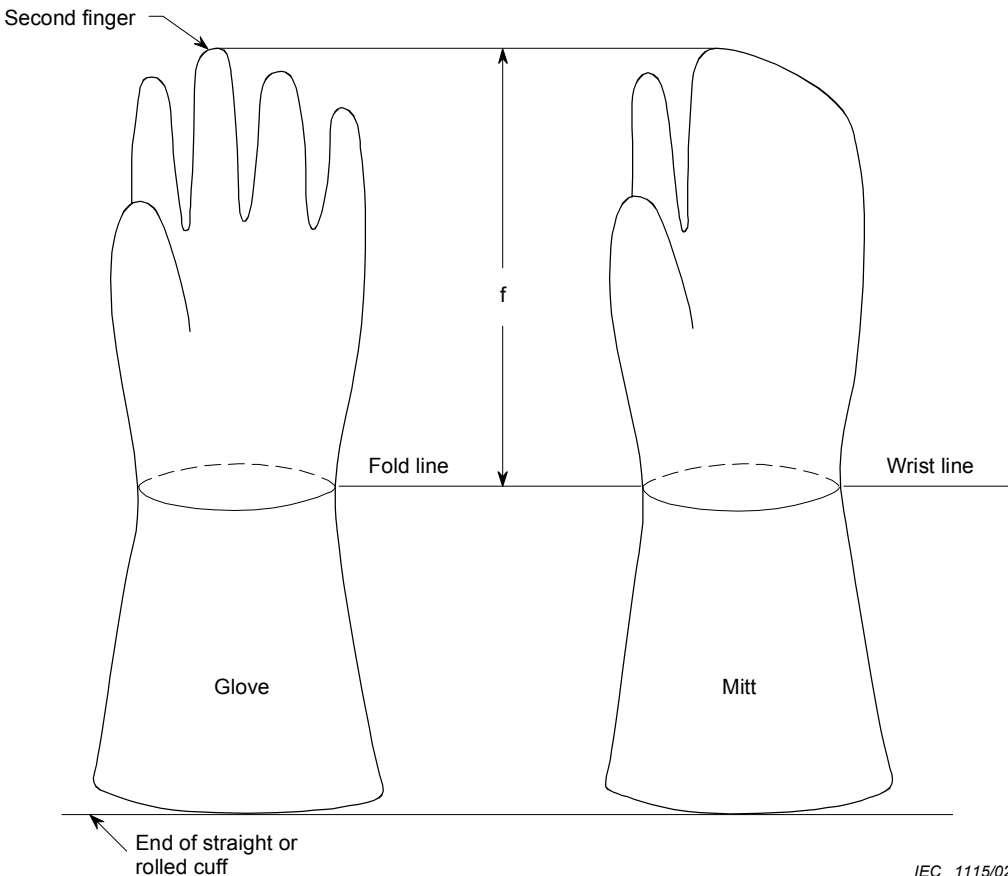
Figure 7 – Test plates and needle for resistance to mechanical puncture (see 8.3.2)



NOTE 1  $D_1$  applies to contour-cuff gloves.

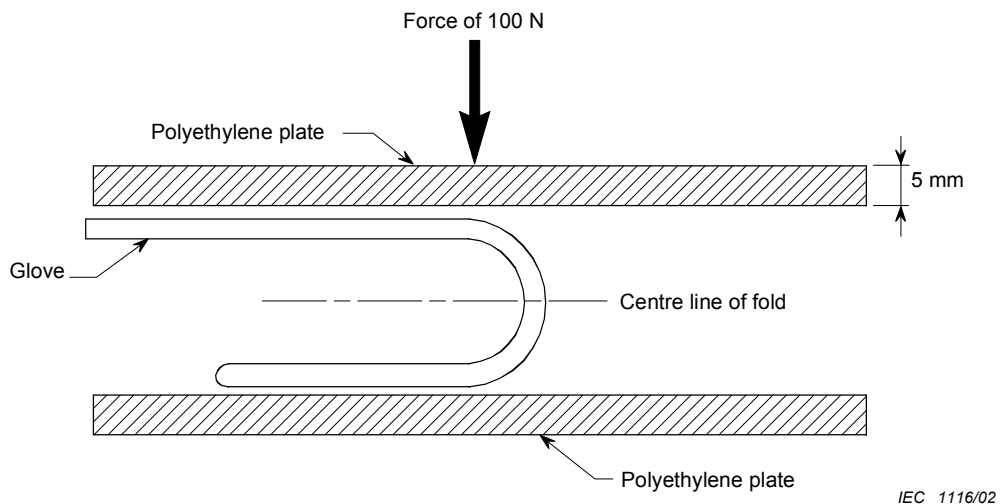
NOTE 2  $D_2$  applies to straight-cuff gloves.

**Figure 8 – Distance  $D$  from open part of glove to water line (see 8.4.1.1)**

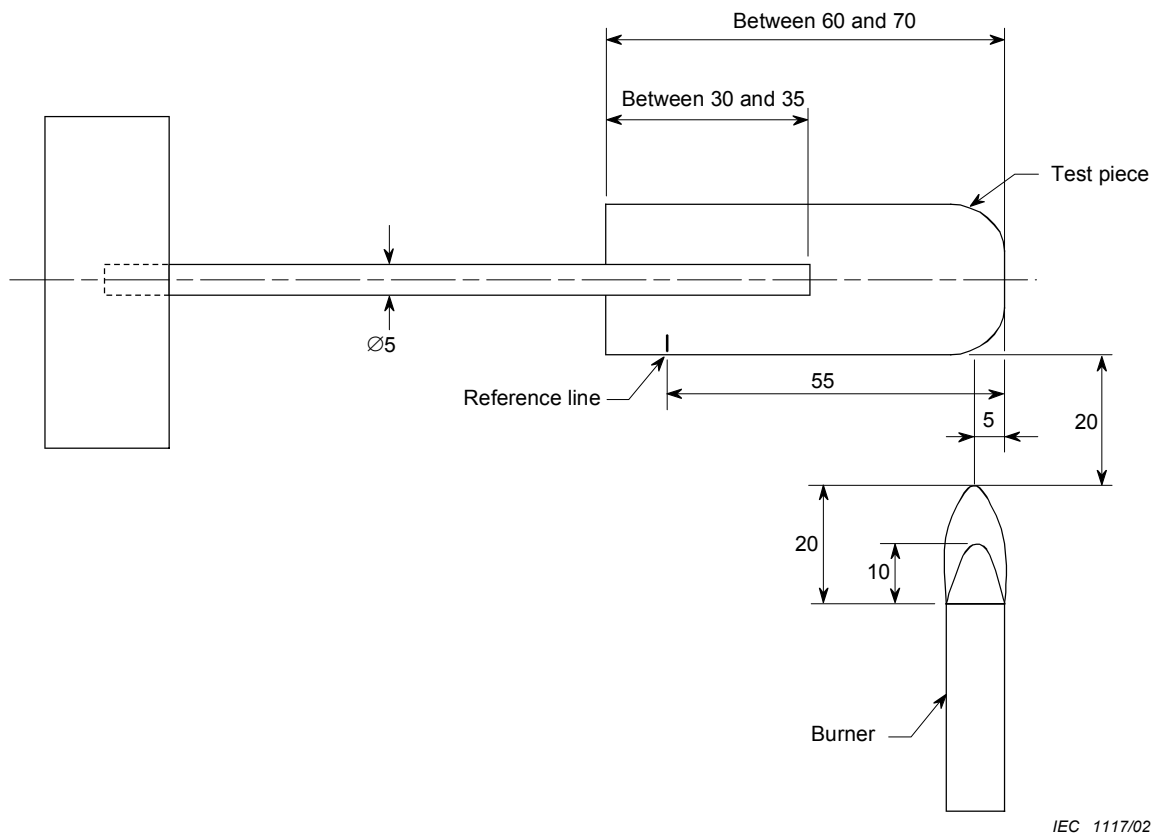


Note For the dimensions that locate wrist, see Figures 1 and 2 and Table F.1.

**Figure 9 – Bend (fold) line for low and extremely low temperature test (see 8.6.1 and 8.7.4)**

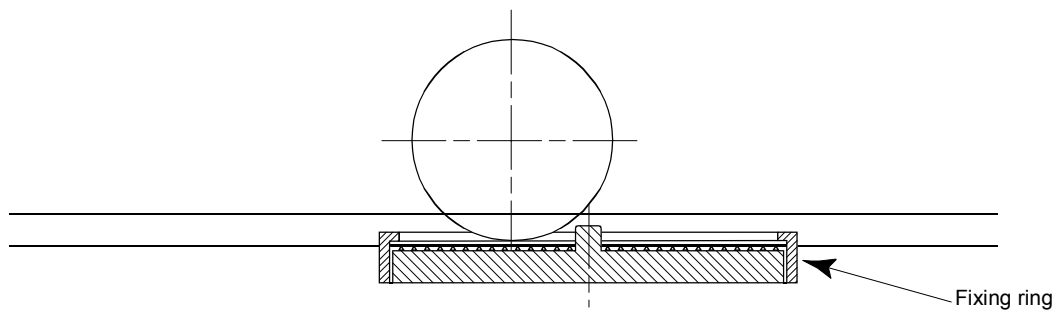


**Figure 10 – Polyethylene plates for low and extremely low temperature test (see 8.6.1 and 8.7.4)**



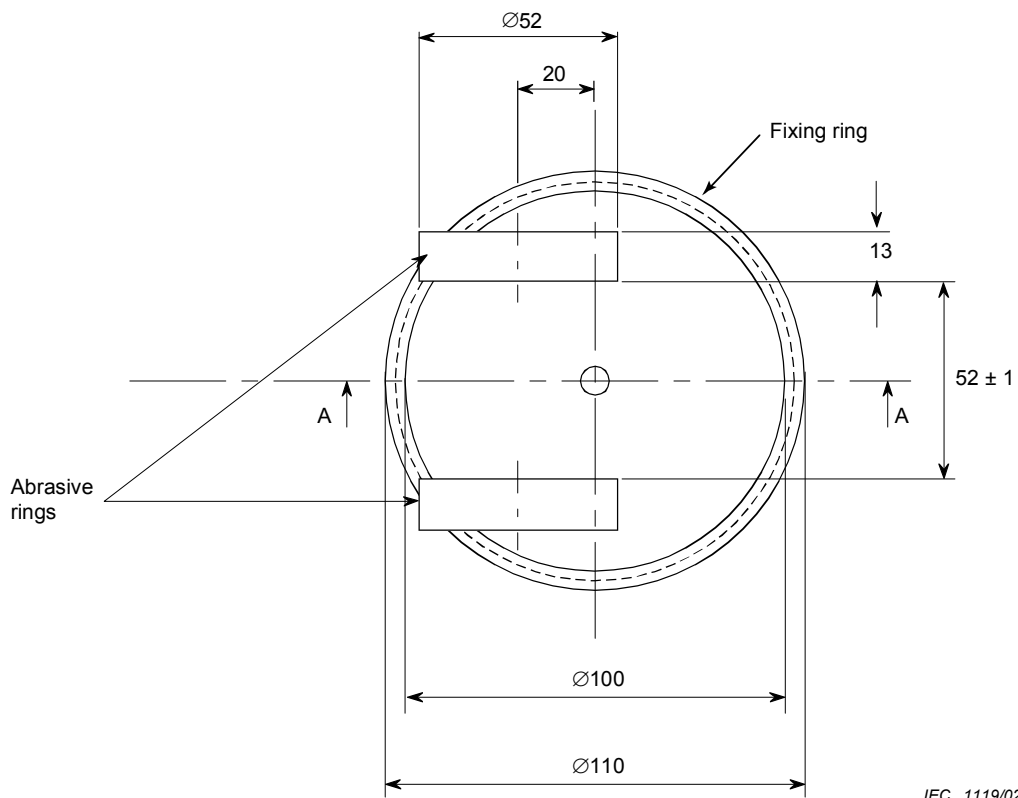
*Dimensions in millimetres*

**Figure 11 – Set-up for the flame retardancy test (see 8.6.2)**



IEC 1118/02

Figure 12a – View A-A

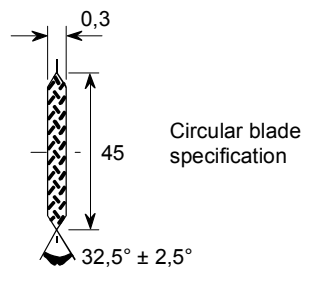
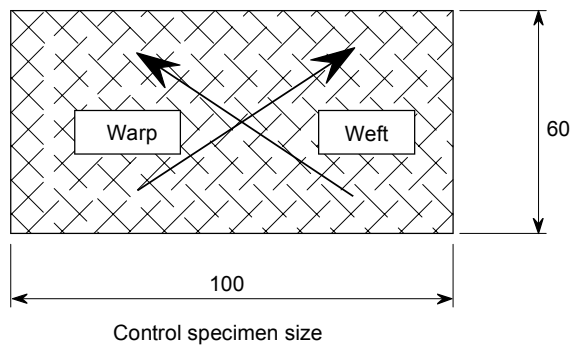
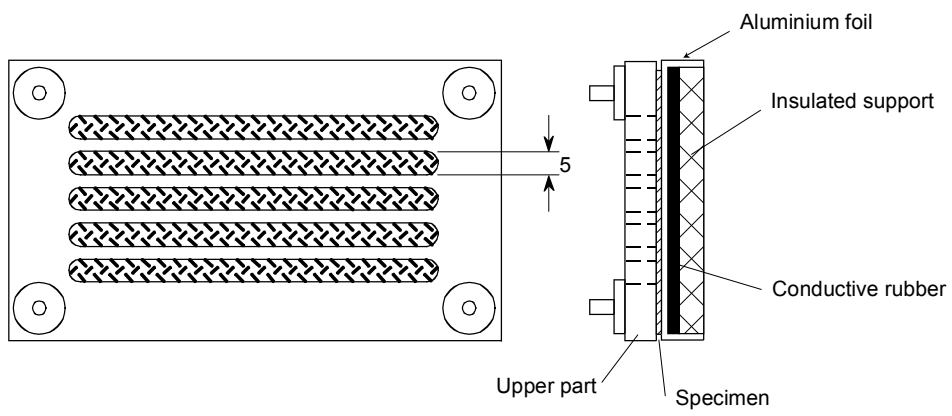
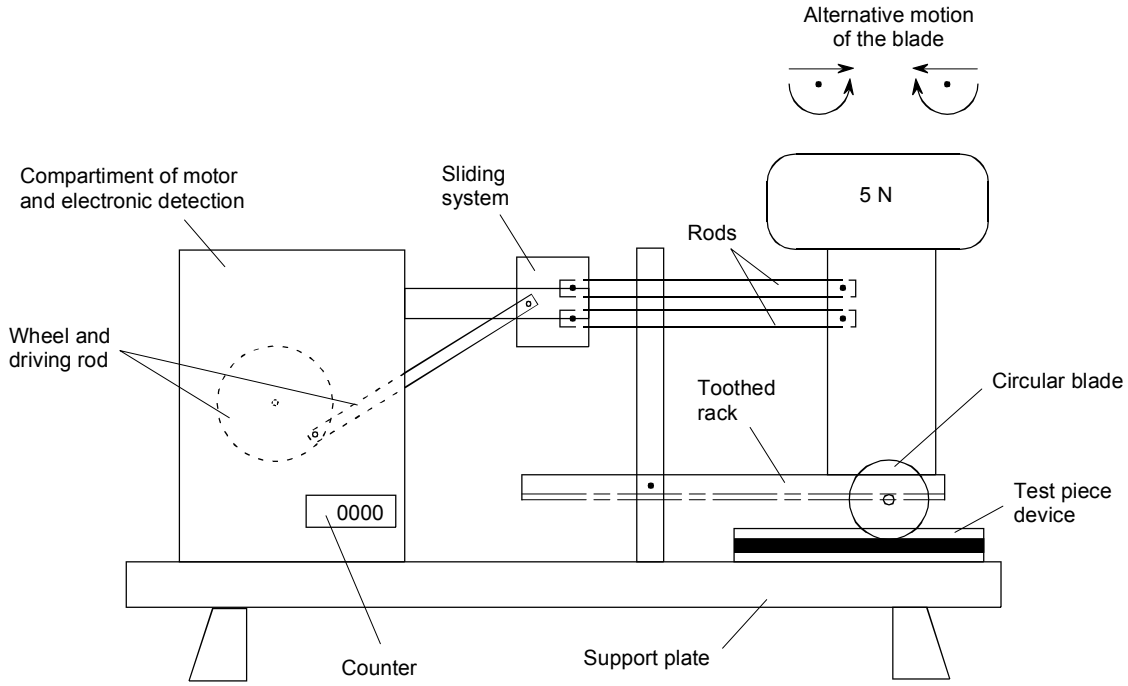


IEC 1119/02

Figure 12b – Top view

*Dimensions in millimetres*

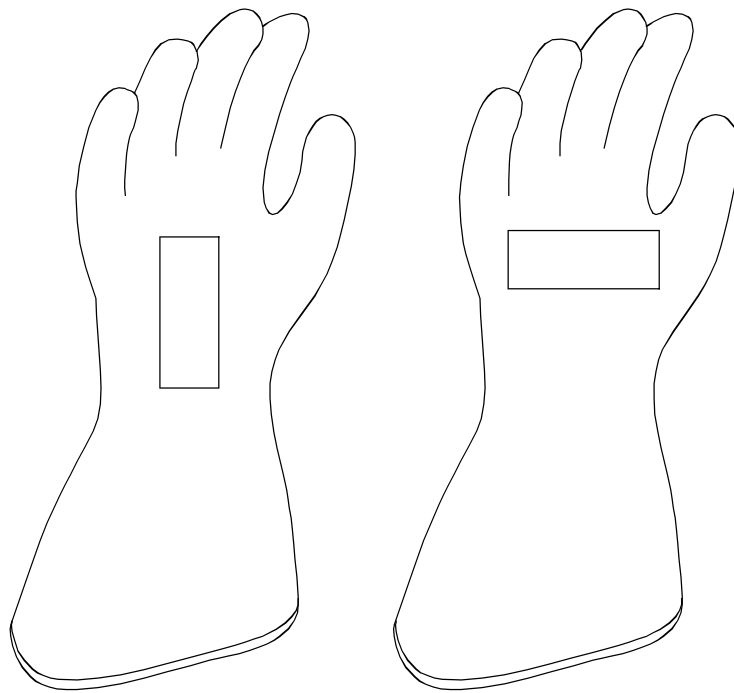
**Figure 12 – Abrasion resistance tester (see 9.1)**



IEC 1120/02

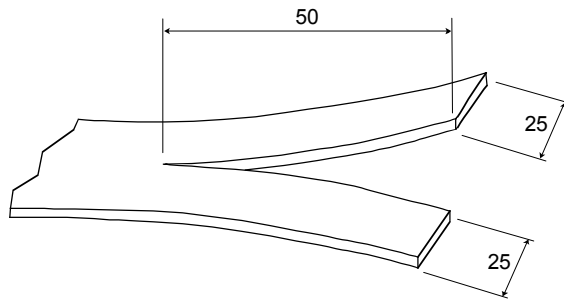
Dimensions in millimetres

**Figure 13 – Apparatus for testing cutting resistance (see 9.2)**



IEC 1121/02

**Figure 14 – Test piece direction and location for tear resistance (see 9.3)**

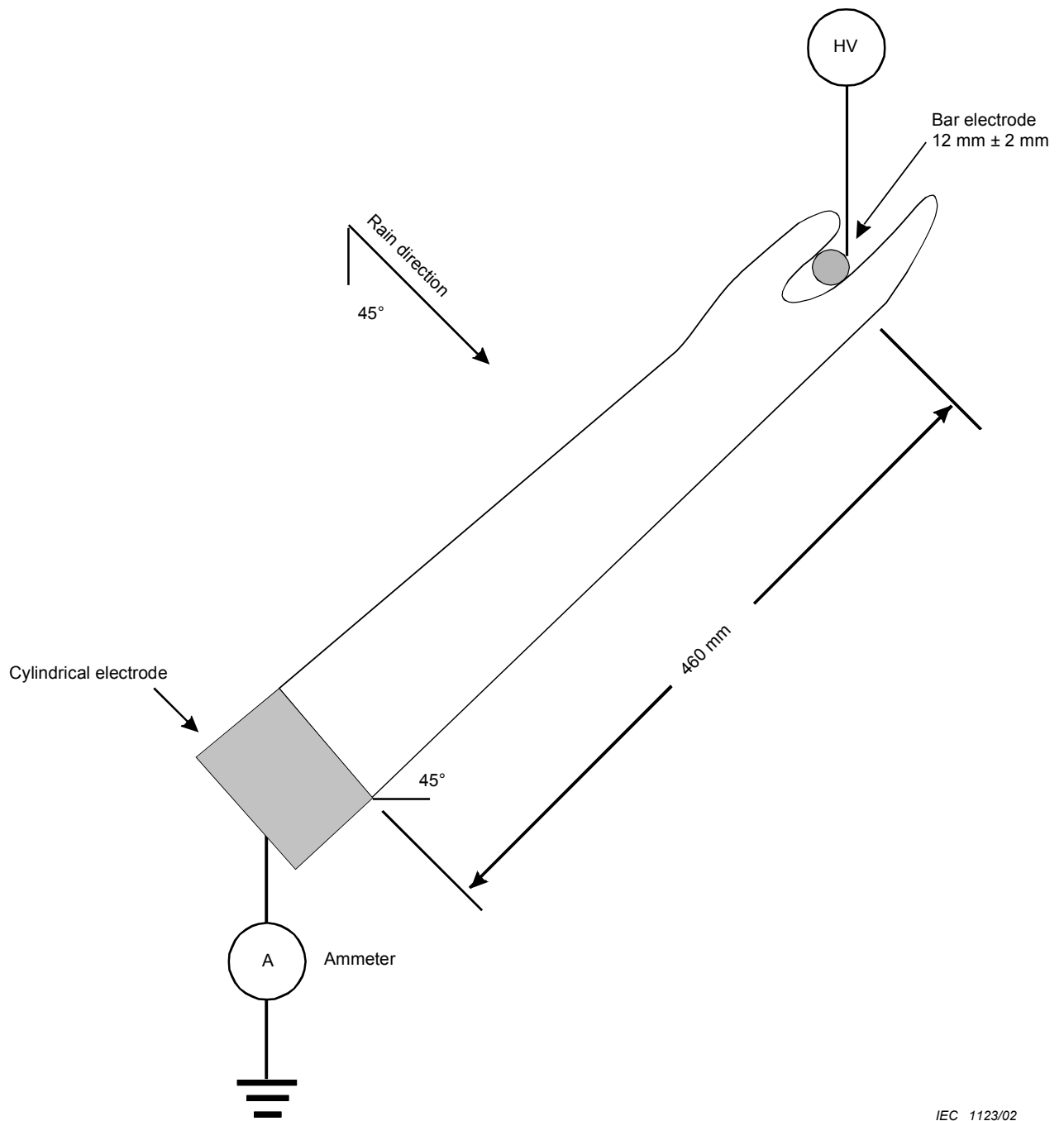


IEC 1122/02

*Dimensions in millimetres*

**Figure 15 – Shape of test piece for tear resistance (see 9.3)**





IEC 1123/02

Figure 16 – Set-up for the leakage current test (see 10.2)

## Annex A (normative)

### List and classification of tests

**Table A.1 – General test procedure**

Type of test	Subclause	Type tests								Routine tests
		Lot 1	Lot 2	Lot 3 R	Lot 4	Lot 5 A	Lot 6 H	Lot 7 Z	Lot 8	
Visual inspection and measurements: - shape - dimensions - thickness - workmanship and finish - marking - packaging	8.2.1 8.2.2 8.2.3 8.2.4 8.8 8.9	1 2 3 4 5 6	1	1	1	1	1	1	1	1
Mechanical tests: - tensile strength and elongation at break - puncture resistance - tension set	5.2.1 – 8.3.1 6.1.1 – 8.3.2 5.2.2 – 8.3.3	7 8 9								
Long composite gloves: - leakage current test  Dielectric tests: - AC test procedure - DC test procedure	10.3  8.4.2 8.4.3	 3  2 <sup>a</sup> 2 <sup>a</sup>								2 <sup>a</sup> 2 <sup>a</sup>
Ageing test	5.4 – 8.5	10								
Thermal tests: - low temperature - flame retardancy	8.6.1 8.6.2	11			2 <sup>b</sup>					
Special properties: - cat. A - Acid resistance - cat. H - Oil resistance - cat. Z - Ozone resistance - cat. C – extremely low temperature resistance - cat. R – Acid, oil, ozone resistance	5.6.1 – 8.7.1 5.6.2 – 8.7.2 5.6.3 – 8.7.3 5.6.5 – 8.7.4 5.6.4			2	2 <sup>b</sup>	2	2	2		
Mechanical – Composite gloves: - puncture resistance - abrasion resistance - cutting resistance - tear resistance	6.2.1 – 8.3.2 6.2.2 – 9.1 6.2.3 – 9.2 6.2.4 – 9.3								2 3 4 5	
Size of each lot (unit is the glove)		7	3	8	3	3	3	2	12	
<sup>a</sup> The choice of whether to carry out the tests in a.c. or d.c. should be agreed between the manufacturer and the customer. <sup>b</sup> Values specified are different in the case of gloves of category C.										
NOTE 1 The acceptance tests are made by agreement between manufacturer and customer. NOTE 2 The numbers given in the table indicate the order in which the tests are to be made. NOTE 3 The requirements of the sampling test are the same as those for type tests. The size of each lot for sampling tests is given in Annex C.										

## **A.1 Lot size requirements**

### **A.1.1 Lot 1**

Lot 1 requires seven suitable gloves.

Three gloves are used for the visual inspection and measurements. One of the three gloves is then used to provide the necessary samples for the tensile strength and elongation tests, one for the tension set test and the third for the puncture resistance tests and the flame retardancy test.

Four gloves are required for the ageing tests. The test pieces for the mechanical tests are cut from two gloves and together with the other two gloves are exposed to the heat in the air oven. Following the required exposure, the test pieces are submitted to the mechanical tests and the two gloves to the dielectric tests.

### **A.1.2 Lot 2**

Lot 2 requires three gloves to be given first the routine thickness measurement.

For normal short gloves, the a.c. or d.c. dielectric proof test (voltage and current) is performed. The withstand test is then performed.

For long composite gloves, the leakage current test is performed in addition to the required dielectric tests.

### **A.1.3 Lot 3**

Lot 3 (for category R gloves) requires eight gloves.

All gloves shall have their thickness measured. Three gloves are exposed to contaminant of category A, three gloves to contaminant of category H and two gloves are submitted to the ozone resistance test. Test pieces are taken from one of each of the gloves exposed to contaminants A and H for the required mechanical tests. The two gloves exposed to the ozone test shall be examined for ozone damage and then these gloves and the remaining gloves submitted to the dielectric tests.

### **A.1.4 Lot 4**

Lot 4 requires three gloves to be given the routine thickness measurement and then either a regular low temperature test or the extremely low temperature test of category C. Following the temperature tests, the gloves are given a dielectric test.

### **A.1.5 Lot 5**

Lot 5 (for category A) requires three gloves to be given the routine thickness measurement and then to be submitted to the acid exposure. Following exposure, one glove provides samples for the mechanical tests and two gloves are submitted to the dielectric tests.

### **A.1.6 Lot 6**

Lot 6 (for category H) requires three gloves to be given the routine thickness measurement and then to be submitted to the oil exposure. Following exposure, one glove provides samples for mechanical tests and two gloves are submitted to the dielectric tests.

**A.1.7 Lot 7**

Lot 7 (for category Z) requires two gloves to be given the routine thickness measurement and then to be submitted to the ozone exposure. Following exposure, gloves are visually inspected and are given the dielectric tests.

**A.1.8 Lot 8**

Lot 8 for composite gloves requires 12 gloves.

All gloves shall have their thickness measured. The test pieces for the puncture resistance test are cut from one glove. The test pieces for the abrasion test are cut from five of the gloves. The test pieces for the cutting resistance test are cut from two of the gloves and the test pieces for the tear resistance test are cut from the four last gloves.

**Annex B**  
(normative)

**Liquid for tests on gloves of category H –  
Oil resistance**

**B.1 Particularities of liquid 102**

Liquid 102 is intended to simulate certain high-pressure hydraulic oils.

It is a blend comprising 95 % (*m/m*) of oil no. 1 and 5 % (*m/m*) of a hydrocarbon-compound oil additive containing 29,5 % (*m/m*) to 33 % (*m/m*) of sulfur, 1,5 % (*m/m*) to 2 % (*m/m*) of phosphorus and 0,7 % (*m/m*) of nitrogen. A suitable additive is commercially available.

**B.2 Characteristics of oil no. 1**

Oil no.1 shall have the characteristics shown in Table B.1. Generally it is of the mineral oil type, and a low volume increase oil.

To ensure uniformity, the source of this oil shall also be specified as a closely controlled blend of mineral oils consisting of a solvent-extracted, chemically treated, dewaxed, paraffinic residuum and natural oil. Oil no. 1 shall not contain any additive, except that a trace (approximately 0,1 %) of a pour-point depressant may be added.

**Table B.1 – Characteristics of oil no. 1**

Property	Oil no. 1
Aniline point (°C) <sup>a</sup>	124 ± 1
Kinematic viscosity (m <sup>2</sup> /s) <sup>b</sup>	(20 ± 1) × 10 <sup>-6</sup>
Flash point (°C minimum) <sup>c</sup>	243
<sup>a</sup> See ISO 2977. <sup>b</sup> Measured at 98,89 °C (see ISO 3104). <sup>c</sup> Measured by Cleveland open cup method (see ISO 2592).	

See ISO 1817 for supplementary information.

## Annex C (normative)

### Sampling procedure

#### C.1 General

The sampling procedure has been specially developed, based on the quality assurance practice of the ISO 9000 series. When the requirements of the ISO 9000 series are not followed, the procedure of this annex is applicable.

NOTE Due to the nature of the product, it is not possible to entirely follow the sampling procedure developed in ISO 2859-1.

#### C.2 Classification of defects

Defects are classified as major or minor (see IEC 61318). Table C.1 gives the nature of defects as a function of the tests retained for the sampling procedure.

**Table C.1 – Classification of defects**

Type of test	Subclause	Type of defect	
		Minor	Major
Visual inspection and measurements: - shape - dimensions - thickness - workmanship and finish - packaging	8.2.1 8.2.2 8.2.3 8.2.4 8.9	x x x x x	
Mechanical tests: - tensile strength and elongation at break - puncture resistance - tension set	5.2.1 – 8.3.1 6.1.1 – 8.3.2 5.2.2 – 8.3.3		x x x
Dielectric tests: - voltage and moisture absorption (current) - AC proof test - AC withstand - DC proof test - DC withstand - long composite glove – leakage current	5.3 – 8.4.1.1 5.3 – 8.4.2.1 <sup>a</sup> 5.3 – 8.4.2.2 <sup>a</sup> 5.3 – 8.4.3.1 <sup>a</sup> 5.3 – 8.4.3.2 <sup>a</sup> 7 – 10.3		x x x x x x
Ageing	5.4 – 8.5	x	
Thermal tests: - low temperature - flame retardancy	8.6.1 8.6.2	x x	
Special properties: - cat. A – Acid resistance - cat. H – Oil resistance - cat. Z – Ozone resistance - cat. C – Extremely low temperature resistance - cat. R – Acid, oil, ozone resistance	5.6.1 – 8.7.1 5.6.2 – 8.7.2 5.6.3 – 8.7.3 5.6.5 – 8.7.4 5.6.4		x x x x x
Mechanical – Composite gloves: - puncture resistance - abrasion resistance - cutting resistance - tear resistance	6.2.1 – 8.3.2 6.2.2 – 9.1 6.2.3 – 9.2 6.2.4 – 9.3		x x x x
<sup>a</sup> The choice of whether to carry out the tests in a.c. or d.c. should be agreed between the manufacturer and the customer.			

### C.3 General sampling plan

#### C.3.1 Plans for minor defects (AQL 10)

**Table C.2 – Sampling plan for minor defects**

Lot	Sample size	Number of defects for acceptance	Number of defects for rejection
2 to 90	5	1	2
91 to 150	8	2	3
151 to 3 200	13	3	4
3 201 to 35 000	20	5	6

NOTE When lot size is less than sampling size, the lot manufactured should be great enough to provide the required sample, e.g. a lot of 2 will require a minimum lot size of 5.

#### C.3.2 Plans for major defects (AQL 4.0)

**Table C.3 – Sampling plan for major defects**

Lot	Sample size	Number of defects for acceptance	Number of defects for rejection
2 to 90	3	0	1
91 to 3 200	13	1	2
3 201 to 35 000	20	2	3

NOTE When lot size is less than sampling size, the lot manufactured should be great enough to provide the required sample, e.g. a lot of 2 will require a minimum lot size of 3.

### C.4 Sampling procedure for gloves with special properties

A first sample of gloves with special properties shall be selected in accordance with the sampling plans given in Tables C.2 and C.3.

In addition, a second sample shall be selected in accordance with Table C.2 and submitted to the tests given in Clause 8, for each respective special category.

### C.5 Procedure when testing is carried out in a laboratory other than the manufacturer's

If, while conducting the dielectric tests, the gloves in a lot or batch fail to meet the requirements of 8.4, the testing shall be terminated and the manufacturer or supplier notified.

In such a case, the manufacturer or supplier may ask the customer or testing laboratory to submit proof that the test procedure and equipment conform to the applicable clauses of this standard.

When such proof has been established, the manufacturer or supplier may request that a representative witness the testing of additional gloves from the shipment.

All rejected lots shall be returned as directed by the manufacturer or supplier without permanent marking. However, gloves punctured, when tested in accordance with 8.4, shall be stamped, punched or cut prior to being returned to the supplier to indicate that they are unfit for electrical use.

## Annex D (informative)

### Guidelines for the selection of the class of glove in relation to nominal voltage of a system

The maximum use voltage recommended for each class of gloves is designated in Table D.1.

**Table D.1 – Designation of maximum use voltage**

Class	AC V rms	DC V
00	500	750
0	1 000	1 500
1	7 500	11 250
2	17 000	25 500
3	26 500	39 750
4	36 000	54 000

The maximum use voltage is the a.c. voltage (r.m.s.) rating of the protective equipment that designates the maximum nominal voltage of the energized system that may be safely worked. The nominal voltage is equal to the phase-to-phase voltage on multiphase circuits.

If there is no multiphase exposure in a system area, and the voltage exposure is limited to the phase (polarity on d.c. systems) to ground potential, the phase (polarity on d.c. systems) to ground potential, shall be considered to be the nominal voltage.

If electrical equipment and devices are insulated, or isolated, or both, such that the multiphase exposure on an earthed, neutral star circuit (grounded wye circuit) is removed and if supplemental insulation (e.g. insulated aerial device or structure-mounted insulating work platform) is used to insulate the worker from ground, then the nominal design voltage may be considered as the phase-to-ground voltage on that circuit.

The user may decide to use a different class of glove than that recommended in Table D.1.

NOTE The maximum voltages have been determined so that leakage current is less than 1 mA in normal use conditions.

Use of plastic and elastomer gloves on d.c. systems:

Caution should be exercised in the use of plastic and elastomer gloves on d.c. systems due to lack of data at the present time.



## Annex E (informative)

### In-service recommendations

The following is for guidance only for the maintenance, inspection, retest and use of gloves after purchase.

#### E.1 Storage

Gloves should be stored in their container or package (see 5.8). Care should be taken to ensure that gloves are not compressed, folded, or stored in proximity to steam pipes, radiators or other sources of artificial heat or exposed to direct sunlight, artificial light or other sources of ozone. It is desirable that the ambient temperature be between 10 °C and 21 °C.

#### E.2 Examination before use

Each time before use, both gloves of a pair should be visually inspected and subjected to a manually applied air test, where practicable. If either glove is thought to be unsafe, the pair should not be used and should be returned for testing.

#### E.3 Temperature

Standard gloves should be used in areas having ambient temperatures between –25 °C and +55 °C, and category C gloves should be used in ambient temperatures between –40 °C and +55 °C.

#### E.4 Precautions in use

Gloves should not be exposed unnecessarily to heat or light, or be allowed to come in contact with oil, grease, turpentine, white spirit or strong acid.

If protector gloves are worn over rubber insulating gloves, they should be sized and shaped so that the insulating glove will not be deformed from its natural shape. The minimum distance between the cuff of the protector glove and the top of the cuff of the insulating glove should not be less than that specified in Table E.1.

**Table E.1 – Distances between the cuff of the protector glove and the top of the cuff of the insulating glove**

Class	Minimum distance mm
00, 0	13
1	25
2	51
3	76
4	102
NOTE Distance should be increased by 25 mm for class 3 and 4 products used on d.c. systems.	

Protector gloves that have been used for any other purpose should not be used to protect insulating gloves. Protector gloves should not be used if they have holes, tears or other defects that affect their ability to give mechanical protection to the insulating glove. Care should be exercised to keep the protector glove free from any contamination that may injure the insulating glove. Contaminated protector gloves should not be used unless they have been thoroughly cleaned of the contaminating substance. The inner surface of the protector gloves should be inspected for sharp or pointed objects; this inspection should be made as often as the insulating gloves are inspected.

When gloves become soiled, they should be washed with soap and water at a temperature not exceeding that recommended by the glove manufacturer, and then thoroughly dried. If insulating compounds, such as tar and paint, continue to stick to the glove, the affected parts should be wiped immediately with a suitable solvent, avoiding excessive solvent use, and then immediately washed and dried as described above.

Gloves which become wet in use or by washing shall be dried thoroughly, but not in a manner that will cause the temperature of the gloves to exceed 65 °C.

### **E.5 Periodic inspection and electrical re-testing**

No gloves of classes 1, 2, 3 and 4, not even those held in storage, should be used unless they have been tested within a maximum period of six months. The most common periods currently range from 30 days to 90 days.

The tests consist of air inflation to check for air leaks, a visual inspection while pressurized, and then a routine dielectric test in accordance with 8.4.2.1 and 8.4.3.1, and 10.3 for the long composite glove.

For class 00 and class 0 gloves, a check for air leaks and a visual inspection may be considered adequate. However, a routine dielectric test may be performed at the owner's request.

For lined gloves, the test should be carried out by means of an appropriate tester to make sure that gloves are not defective.

## Annex F (informative)

### Typical glove dimensions

**Table F.1 – Details and dimensions (see Figures 1 and 2)**

Detail	Dimensions mm				
	Letter	Size			
		8	9	10	11
Circumference					
- of palm	a	210	235	255	280
- of wrist	c	220	230	240	255
- of cuff	d	330	340	350	360
Length of gloves	e	See note			
Circumference of fingers	i	70	80	90	95
	j	60	70	80	85
	k	60	70	80	85
	l	60	70	80	85
	m	55	60	70	75
Width of palm	b	95	100	110	125
Wrist to end of second finger	f	170	175	185	195
Base of thumb to end of second finger	g	110	110	115	120
Mid-point of curve of second finger	h	6	6	6	8
Length of fingers	n	60	65	70	70
	o	75	80	85	85
	p	70	75	80	80
	q	55	60	65	65
	r	55	60	65	65
	t	15	17	17	17
NOTE Dimension "e" varies according to voltage class and desire of customer (see Table 4).					

## Annex G (informative)

### Cotton canvas additional characteristics

Table G.1 gives additional characteristics and specifications of cotton canvas from which the test specimens are cut and used in the blade cut resistance test of 9.2.

These values are obtained with the method and apparatus known worldwide as KESF (Kawabata Evaluation System for Fabrics).

The polymerization of the cotton used is  $2\ 000 \pm 50$ .

KESF test (Kawabata evaluation system for fabrics):

<b>Tensile</b>	(Tensile cycle, maximum tensile stress limit of which is 1 000 gf/cm) LT: linearity (characterize the elasticity 1 for the spring) WT: tensile energy in J/m RT: resiliency, i.e. percentage of recovered energy
<b>Bending</b>	(Alternate bending cycle on a sample placed vertically) B: Bending stiffness 2HB: Bending hysteresis at $1\text{ cm}^{-1}$ of curvature
<b>Shear</b>	(Alternate deformation of a rectangular sample in a parallelogram, the angle of which is $8^\circ$ ) G: shear stiffness 2HG and 2HG5: shear hysteresis at $0,5^\circ$ and $5^\circ$ of deformation
<b>Compression</b>	(Compression cycle of the thickness, the maximum limit of which is $-5,0\text{ kPa}$ ) LC: linearity (characterize the elasticity 1 for the spring) WC: compression energy in $\text{J/m}^2$ RC: resiliency, i.e. the percentage of recovered energy
<b>Surface</b>	(Characterization of a surface with sensors of $25\text{ mm}^2$ (friction coefficient) and 5 mm width (roughness)) MIU: mean value of the friction coefficient MMD: mean deviation of the friction coefficient SMD: mean value of the surface roughness in micrometres

**Table G.1 – Identification sheet**  
**Reference sample – Cotton weave fabric**

KESF		Characteristics values				Settings for the tests		
Tests	Parameters	Units	Warp	Weft	Size	Stress	Speed	
Tensile	LT	-	0,98 – 1,04	0,98 – 1,04	200 mm x 50 mm	Maximum strain is 1 000,00 gf/cm (see note)	0,2000 cm/s	
	WT	J/m	15 – 25	7 – 8				
	RT	%	49 – 50	52 – 53				
Bending	B	$\mu\text{N}\times\text{m}$	300 – 350	490 – 530	10 mm x 50 mm	Maximum curvature is $\pm 2,5$ cm	0,5 $\text{cm}^{-1}/\text{s}$	
	2HB	mN	40 – 50	45 – 55				
Shearing	G	$\text{N}/\text{m}^\circ$	20 – 30	20 – 30	500 mm x 50 mm	Tension is 1 000 g	0,478 $^\circ/\text{s}$	
	2 HG	$\text{N}/\text{m}$	45 – 60	45 – 60		Maximum angle is $\pm 8,0^\circ$		
	2 HG5	$\text{N}/\text{m}$	45 – 55	45 – 55				
Compression	LC	-	0,43 – 0,49	0,43 – 0,49	2 $\text{cm}^2$	Maximum pressure is 5,00 kPa	0,00200 cm/s	
	WC	$\text{J}/\text{m}^2$	0,21 – 0,25	0,21 – 0,25				
	RC	%	32 – 38	32 – 38				
Surface	MIU	-	0,200 – 0,210	0,200 – 0,210	5 mm x 20 mm	Tension is 600 g	1 mm/s	
	MMD	-	0,035 – 0,050	0,035 – 0,050	5 mm x 20 mm	P = 50 gf/25 $\text{mm}^2$		
	SMD	$\mu\text{m}$	160 – 200	80 – 100	5 mm x 20 mm	P = 10 gf/5 $\text{mm}^2$		
Thickness	Te	mm	1,20 – 1,35	1,20 – 1,35	2 $\text{cm}^2$	P = 0,05 kPa	0,00200 cm/s	
Weight	W	$\text{g}/\text{m}^2$	520 – 540					

NOTE "gf" stands for gram-force. 1 000 gf = 9,806 N.

## **Annex H** (informative)

### **Acceptance tests**

As defined in IEC 60050(151) [IEV 151-16-23], an acceptance test is a contractual test to prove to the customer that the device meets certain conditions of its specification. These tests may be carried out on every unit (routine tests) or on a sampling of the units (sampling tests).

If a customer indicates in his specification that the device must meet this IEC standard only, the acceptance tests (both routine and sampling) are those which are specified in this standard.

The customer may wish to witness the tests, to have someone else witness them or simply accept the results of the tests as carried out by the manufacturer. He may also specify that the tests be carried out in an independent laboratory of his choosing or even his own laboratory.

NOTE The customer may specify additional tests or larger sampling sizes when he is purchasing from a new manufacturer, either because he has experienced problems with a particular manufacturer or because he is purchasing a new product or a new design.

## Annex I (informative)

### Electrical limits for the use of gloves of insulating material

#### I.1 General

The choice of insulating gloves manufactured in accordance with this standard and for use in live working is determined by the following:

- the highest voltage of the system;
- the required insulation level for live working (RILL);
- the supplemental protective insulating equipment utilized by the worker;
- the work practices required by the employer and utilized by the employee.

#### I.2 Limits when no additional tests are made

Table I.1 gives the various electrical components or limits affecting the choice of insulating gloves to be utilized.

$U_s$  is the operational phase-to-phase voltage as specified for the system.

$U_t$  is the r.m.s. withstand test voltage of the class of insulating gloves.

RILL is a calculated switching impulse  $U_{90}$  crest voltage withstand.

On an earthed, neutral star circuit (grounded wye circuit), if multiphase exposure is removed from the working area because electrical conductors and equipment are insulated or isolated, or both, the phase-to-earth voltage can be considered the nominal voltage.

When the insulating glove rating complies with the standard for a given class, that class of insulating glove can be used on systems for which the RILL is lower or equal to the value given in Table I.1 for the same class.

Comparative tests (Switching Impulse versus a.c.) performed in laboratories of various countries in the world have shown some equivalence in results between  $U_{90}$  and the a.c. withstand test voltage of the insulating materials used in insulating gloves. A value of 1,3 times the a.c. withstand crest voltage can be used to estimate the impulse withstand rating of the insulating glove.

If the RILL is higher than the estimated impulse rating of the insulating glove, then sufficient supplemental protective insulating equipment should be utilized in series with the employee and between the live line or equipment and earth to bring the estimated impulse withstand rating of the combination higher than  $U_{90}$ .

Under the assumption that the a.c. withstand test has been performed at sea level, the RILL  $U_{90}$  is given by the formula:

$$U_{90} = F \times k_a \times 1,414 \times U_r \text{ in kV peak}$$

where

$U_{90}$  is the switching impulse withstand of the insulating glove;

$F$  is the equivalence factor;

$k_a$  is the altitude factor in accordance with IEC 61472;

$U_r$  is the a.c. r.m.s. withstand test voltage.

The RILL for Table I.1 has been calculated with  $F = 1,3$  and  $k_a = 0,901$  for an altitude of 1 000 m for voltages less than 199 kV.

**Table I.1 – Electrical limits**

Insulating glove Class	Highest operational voltage of the system $U_s$		Withstand test voltage $U_r$ kV rms	RILL $U_{90r}$ kV peak
	kV rms	kV dc		
00	0,5	0,75	4,0	<sup>a</sup>
0	1,0	1,5	10	<sup>a</sup>
1	7,5	11,25	20	25
2	17,0	25,5	30	50
3	26,5	39,75	40	66
4	36,0	54,0	50	83

<sup>a</sup> Not applicable.

NOTE 1 The RILL requires that the insulating glove along with any supplemental protective insulating equipment, at the altitude of the work location, have a  $U_{90}$  at least equal to the value of the RILL, when  $U_{90}$  is the statistical withstand voltage for the standard switching impulse 250/2 500  $\mu$ s with 90 % probability of being withstood. Table I.1 shows the equivalent RILL at 1 000 m above sea level.

NOTE 2 Considering the RILL is a characteristic of power systems and operating systems during live working, it is up to the user to select the appropriate RILL value. Consequently, insulating gloves of classes lower than the one taken from Table I.1, can be used if the system is characterized by a transient withstand value,  $U_{90}$ , lower or equal to the one given in Table I.1 for this class. Conversely, insulating gloves of a given class cannot be used on a power system corresponding to Table I.1, if the RILL value of the system is higher than the one given by Table I.1 for the same class. In such a case, supplemental protective insulating equipment sufficient to raise the impulse rating of the combination equal to or greater than the RILL must be employed.

### I.3 Limits when additional tests are made

Insulating gloves covered by this standard may be used for higher values of RILL than those listed in Table I.1 if it has been proven, by switching impulse type tests, that the insulating gloves have the required withstand voltage  $U_{90}$  for that system's maximum switching impulse stress. The replacement of the impulse test by an a.c. test of different magnitude is not acceptable in this case.

The tests should be performed in accordance with the IEC 60060 series and with test voltages corrected such that the confirmed limit value of the RILL is valid for altitudes up to 1 000 m above sea level.



## Annex ZA (normative)

### Normative references to international publications with their corresponding European publications

This European Standard incorporates by dated or undated reference, provisions from other publications. These normative references are cited at the appropriate places in the text and the publications are listed hereafter. For dated references, subsequent amendments to or revisions of any of these publications apply to this European Standard only when incorporated in it by amendment or revision. For undated references the latest edition of the publication referred to applies (including amendments).

NOTE When an international publication has been modified by common modifications, indicated by (mod), the relevant EN/HD applies.

<u>Publication</u>	<u>Year</u>	<u>Title</u>	<u>EN/HD</u>	<u>Year</u>
IEC 60050-151	2001	International Electrotechnical Vocabulary (IEV) Part 151: Electrical and magnetic devices	-	-
IEC 60050-601	1985	Chapter 601: Generation, transmission and distribution of electricity - General	-	-
IEC 60050-651	1999	Part 651: Live working	-	-
IEC 60060-1 + corr. March	1989 1990	High-voltage test techniques Part 1: General definitions and test requirements	HD 588.1 S1	1991
IEC 60060-2	1994	Part 2: Measuring systems	EN 60060-2 A11	1994 1998
IEC 60212	1971	Standard conditions for use prior to and during the testing of solid electrical insulating materials	HD 437 S1	1984
IEC 60417	database	Graphical symbols for use on equipment	-	-
IEC 60743	2001	Live working - Terminology for tools, equipment and devices	EN 60743	2001
IEC 61318	1994	Live working - Guidelines for quality assurance plans	-	-
IEC 61477	2001	Live working - Minimum requirements for the utilization of tools, devices and equipment	EN 61477	2002
ISO 37	1994	Rubber, vulcanized or thermoplastic - Determination of tensile stress-strain properties	-	-
ISO 472	1999	Plastics - Vocabulary	EN ISO 472	2001

<u>Publication</u>	<u>Year</u>	<u>Title</u>	<u>EN/HD</u>	<u>Year</u>
ISO 2592	2000	Determination of flash and fire points - Cleveland open cup method	EN ISO 2592	2001
ISO 2859-1	1999	Sampling procedures for inspection by attributes Part 1: Sampling schemes indexed by acceptance quality limit (AQL) for lot-by-lot inspection	-	-
ISO 2977	1997	Petroleum products and hydrocarbon solvents - Determination of aniline point and mixed aniline point	-	-
ISO 3104	1994	Petroleum products - Transparent and opaque liquids - Determination of kinematic viscosity and calculation of dynamic viscosity	EN ISO 3104	1996
ISO 9000	2000	Quality management systems - Fundamentals and vocabulary	EN ISO 9000	2000
ISO 9001	2000	Quality management systems - Requirements	EN ISO 9001	2000
ISO 9004	2000	Quality management systems - Guidelines for performance improvements	EN ISO 9004	2000

## **Bibliography**

IEC 61472:1998, *Live working – Minimum approach distances – Method of calculation*

ISO 1817:1999, *Rubber, vulcanized – Determination of the effect of liquids*

ASTM D120-95, *Standard Specification for Rubber Insulating Gloves*

ASTM F496-99, *Standard Specification for In-Service Care of Insulating Gloves and Sleeves*

EN 388, *Protective gloves against mechanical risks*

EN 420, *Protective gloves – General requirements*

---

---

---

## BSI — British Standards Institution

BSI is the independent national body responsible for preparing British Standards. It presents the UK view on standards in Europe and at the international level. It is incorporated by Royal Charter.

### Revisions

British Standards are updated by amendment or revision. Users of British Standards should make sure that they possess the latest amendments or editions.

It is the constant aim of BSI to improve the quality of our products and services. We would be grateful if anyone finding an inaccuracy or ambiguity while using this British Standard would inform the Secretary of the technical committee responsible, the identity of which can be found on the inside front cover. Tel: +44 (0)20 8996 9000. Fax: +44 (0)20 8996 7400.

BSI offers members an individual updating service called PLUS which ensures that subscribers automatically receive the latest editions of standards.

### Buying standards

Orders for all BSI, international and foreign standards publications should be addressed to Customer Services. Tel: +44 (0)20 8996 9001. Fax: +44 (0)20 8996 7001. Email: [orders@bsi-global.com](mailto:orders@bsi-global.com). Standards are also available from the BSI website at <http://www.bsi-global.com>.

In response to orders for international standards, it is BSI policy to supply the BSI implementation of those that have been published as British Standards, unless otherwise requested.

### Information on standards

BSI provides a wide range of information on national, European and international standards through its Library and its Technical Help to Exporters Service. Various BSI electronic information services are also available which give details on all its products and services. Contact the Information Centre. Tel: +44 (0)20 8996 7111. Fax: +44 (0)20 8996 7048. Email: [info@bsi-global.com](mailto:info@bsi-global.com).

Subscribing members of BSI are kept up to date with standards developments and receive substantial discounts on the purchase price of standards. For details of these and other benefits contact Membership Administration. Tel: +44 (0)20 8996 7002. Fax: +44 (0)20 8996 7001. Email: [membership@bsi-global.com](mailto:membership@bsi-global.com).

Information regarding online access to British Standards via British Standards Online can be found at <http://www.bsi-global.com/bsonline>.

Further information about BSI is available on the BSI website at <http://www.bsi-global.com>.

### Copyright

Copyright subsists in all BSI publications. BSI also holds the copyright, in the UK, of the publications of the international standardization bodies. Except as permitted under the Copyright, Designs and Patents Act 1988 no extract may be reproduced, stored in a retrieval system or transmitted in any form or by any means – electronic, photocopying, recording or otherwise – without prior written permission from BSI.

This does not preclude the free use, in the course of implementing the standard, of necessary details such as symbols, and size, type or grade designations. If these details are to be used for any other purpose than implementation then the prior written permission of BSI must be obtained.

Details and advice can be obtained from the Copyright & Licensing Manager. Tel: +44 (0)20 8996 7070. Fax: +44 (0)20 8996 7553. Email: [copyright@bsi-global.com](mailto:copyright@bsi-global.com).